

# NOTICE DE POSE

Espace d'angle Konsilio



## PRÉPARATION



x2



90 minutes

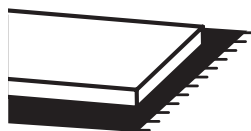

- Veillez à ce que le **sol** de l'emplacement soit de niveau.
- L'espace de montage doit être **propre** et **dégagé**, prévoir **3m x 3m** au sol.

## OUTILS

NON FOURNIS :



Maillet

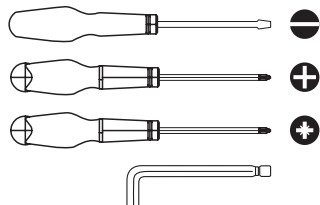

Tournevis et clé 6 pans



Visseuse



Perceuse

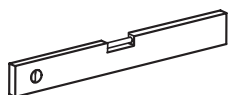

Niveau à bulle



Crayon



Eau savonneuse + chiffon

## QUINCAILLERIE : composition des sachets



**LES CHEVILLES ET VIS DE FIXATION AU MUR NE SONT PAS FOURNIS**

### Sachet pour joue n°825

A	équerre	x1
B	cache	x1
C	tourillon	x2
D	insert métallique	x4
E	goujon fil métal	x4
F	vis	x2

### Sachet pour joue d'angle n°849

D	insert métallique	x8
E	goujon fil métal	x8
C	tourillon	x6

### Sachet pour plinthe n°801

G	clip de plinthe	x2
H	support clip de plinthe	x2
F	vis	x4

### Sachet pour tasseau n°832

S	vis	x6
---	-----	----

### Sachet pour tasseau d'angle n°846

D	insert métallique	x3
E	goujon fil métal	x3
K	excentrique*	x3
S	vis	x3

### Sachet pour piétement tablette basse n°826

I	embase	x4
J	piéd	x4
F	vis	x16

### Sachet pour tablette fixe n°827

K	excentrique*	x4
---	--------------	----

### Sachet pour tablette semi-fixe n°804

L	boîtier	x4
M	goujon	x4

### Sachet pour tablette semi-fixe d'angle n°847

T	goujon double	x2
C	tourillon	x2
L	boîtier	x2
M	goujon	x2

### Sachet pour tablette fixe d'angle n°848

T	goujon double	x2
---	---------------	----

### Sachet pour tringle n°828

P	support tringle	x2
F	vis	x2

### Sachet pour tringle d'angle n°850

U	coude de jonction	x1
V	support sous tablette	x1
F	vis	x2

### Sachet pour montant central n°834

Q	ferrure femelle	x5
R	ferrure mâle	x5
F	vis	x20

\* Un sachet de caches excentrique est également fourni. Utilisez le pour masquer les excentriques (repère K page suivante) à la fin du montage

N° de sachet	825	849	801	832	846	826	827	804	847	848	828	850	834
Quantité	2	1	2	1	4	2	9	2	1	4	2	1	2

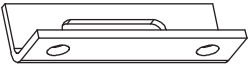
**A**  x2

**B**  x2

**C**  x12

**D**  x40

**E**  x28

**F**  x94

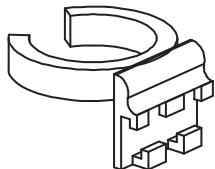
**G**  x4

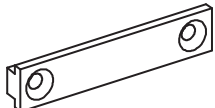
**H**  x4

**K**  x48

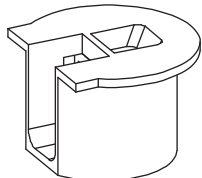
**L**  x10

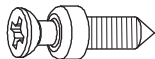
**M**  x10

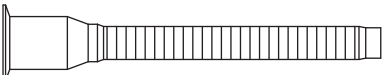
**S**  x18

**P**  x4

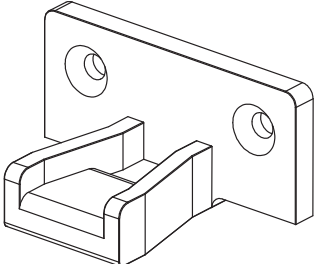
**Q**  x10

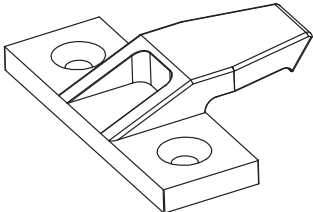
**R**  x10

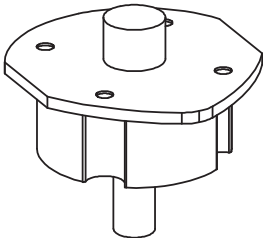
**I**  x8

**T**  x10  
 ▲ Retirer les circlips sur les goujons double avant utilisation.

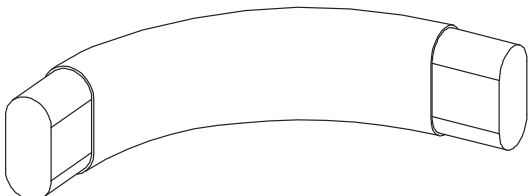
**U**  x1

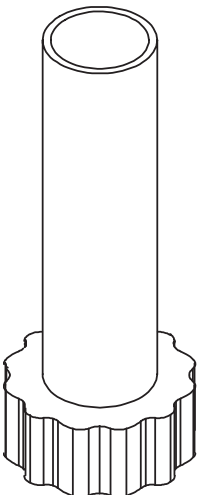
**J**  x8

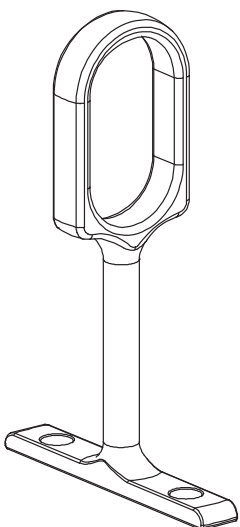
**V**  x1

# NUMÉROTATION DES PIÈCES : repères

2 et 16 : largeur 100 mm

21 et 22 : largeur 122 mm

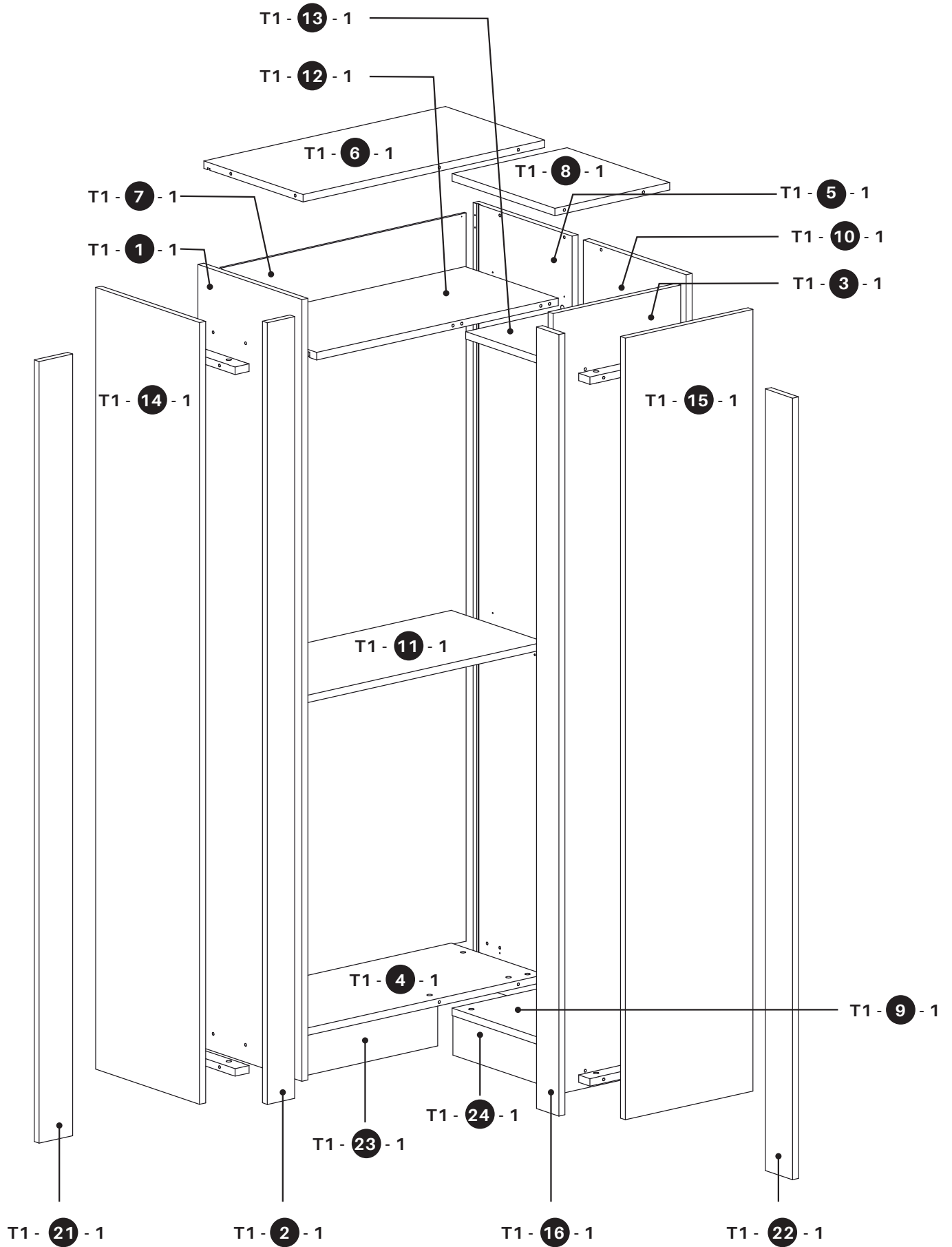

# NUMÉROTATION DES PIÈCES

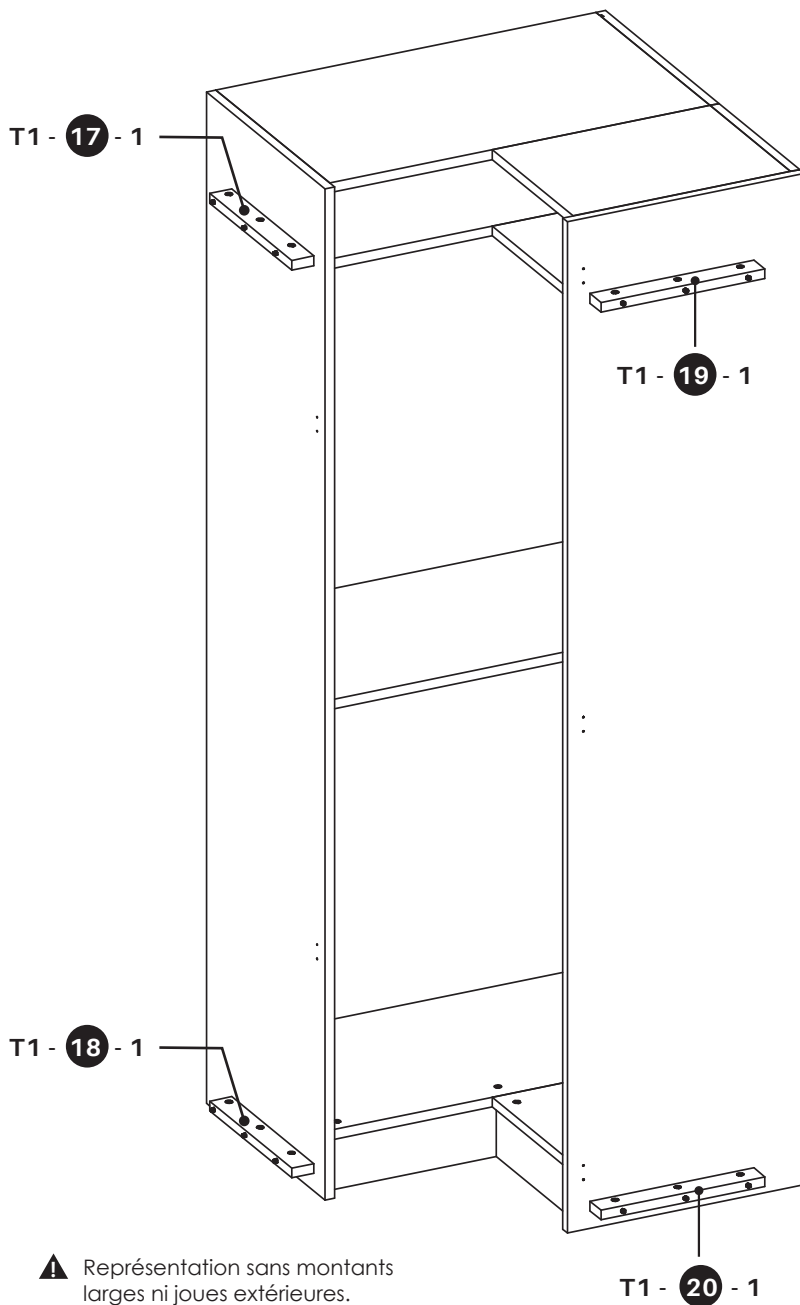

# IDENTIFICATION DES PIÈCES

CCOK244603	AM006235
CPHL	
MME DUPONT	810891
SP4018164	J01 1 18/07/2022



Repère  
T1-1-1  
N° Module

T1 - 1 - 1

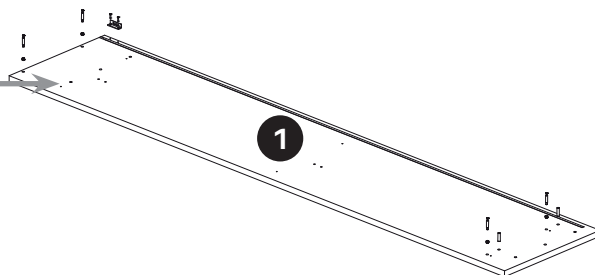

2445 x 465 x 22	OF10039732
Collection rangement Konsilio 1 espace d'angle	
Blanc Mat Colis 2 Joue Gauche	

ÉTIQUETTE PRODUIT

NUMÉROTATION NOTICE

# 1.

OUTILS	
tournevis	+
maillet	

QUINCAILLERIE		
Sachet n°825		
A	équerre	x1
C	tourillon	x2
D	insert métallique	x4
E	goujon fil métal	x4
F	vis	x2

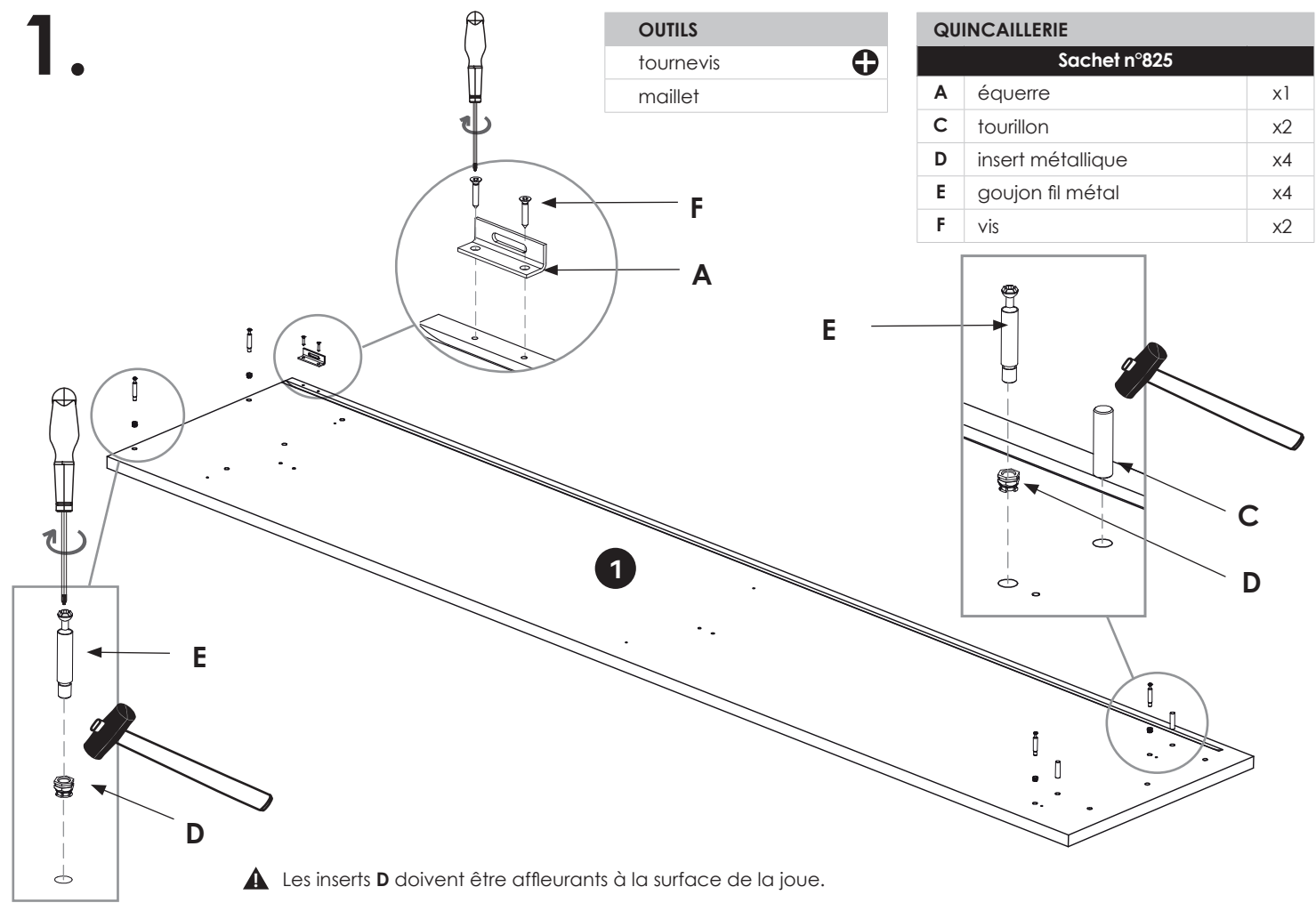

⚠ Les inserts **D** doivent être affleurants à la surface de la joue.

# 2.

OUTILS	
tournevis	+

QUINCAILLERIE		
Sachet n°826		
I	embase	x4
F	vis	x16

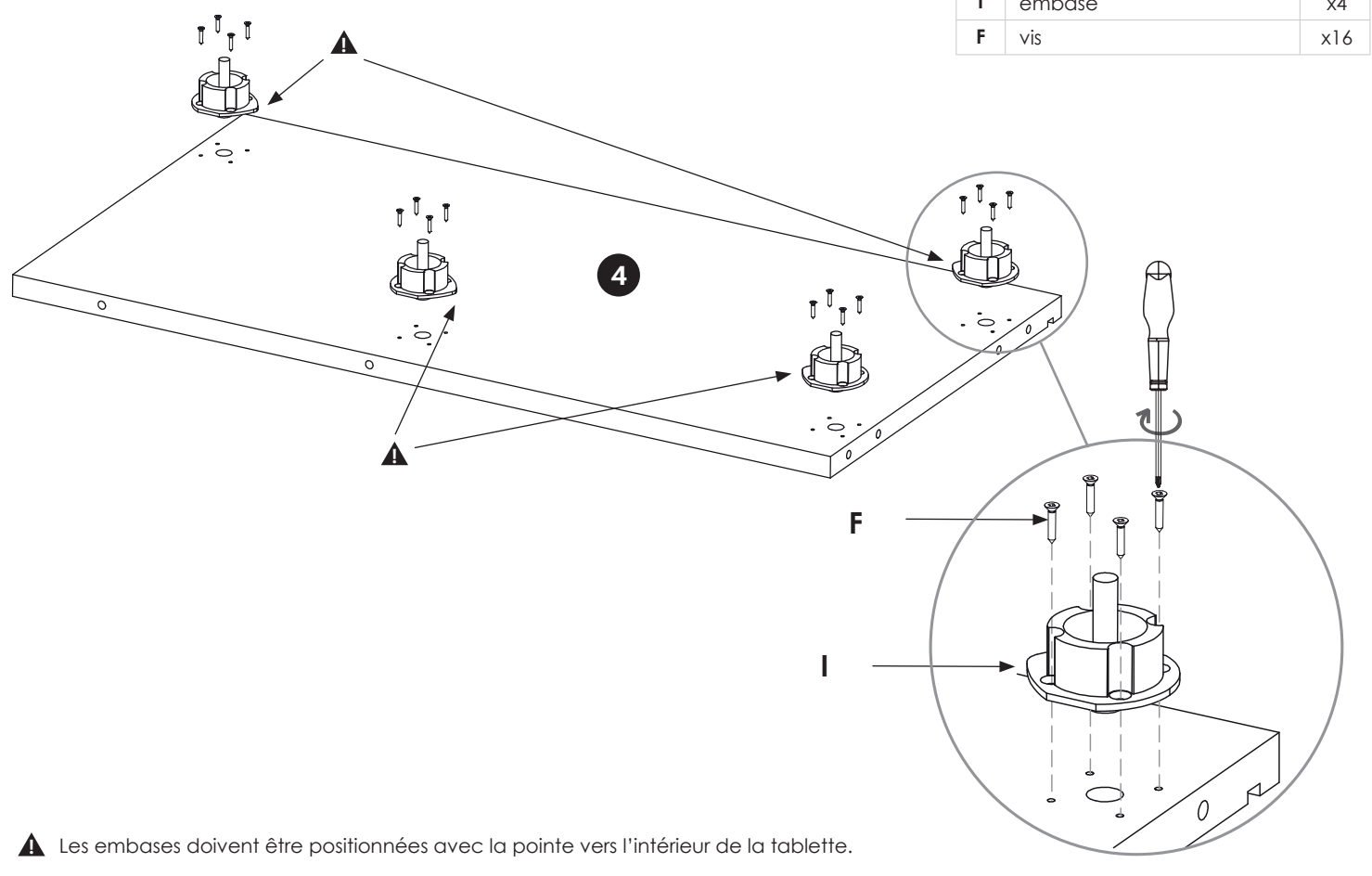

⚠ Les embases doivent être positionnées avec la pointe vers l'intérieur de la tablette.

# 3.

QUINCAILLERIE

Sachet n°826

J pied

x4

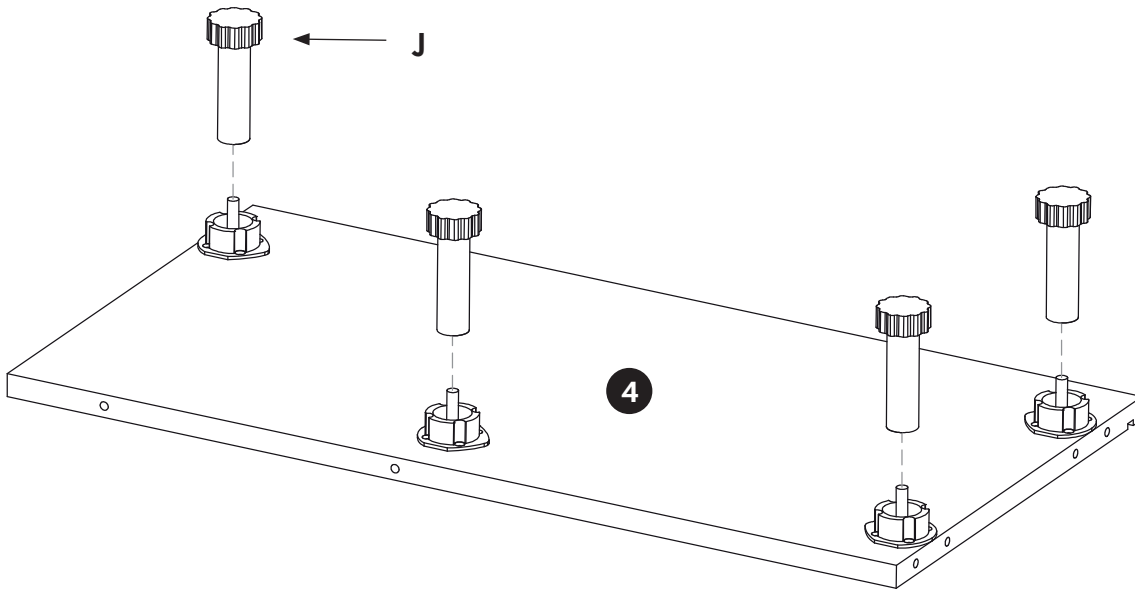

# 4.

Ajuster la longueur des pieds de réglage pour que la tablette 4 se trouve à 123 mm du sol, cette position pouvant varier selon la planéité du sol.

QUINCAILLERIE

Sachet n°827

x1½

K excentrique

x6

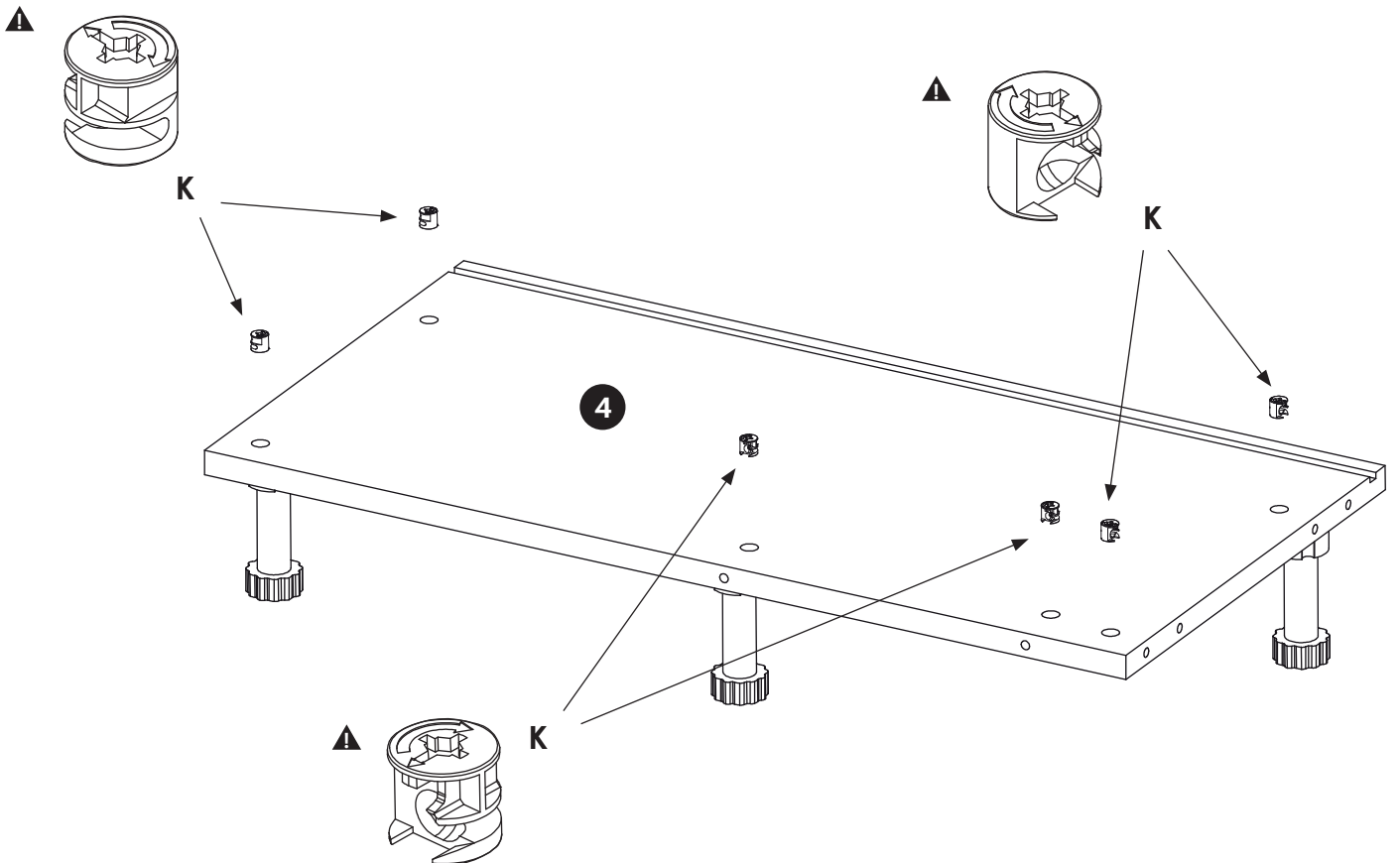

⚠ La flèche des excentriques est orientée vers l'extérieur de la tablette.

# 5.

## QUINCAILLERIE

	Sachet n°827	x1½
K	excentrique	x6

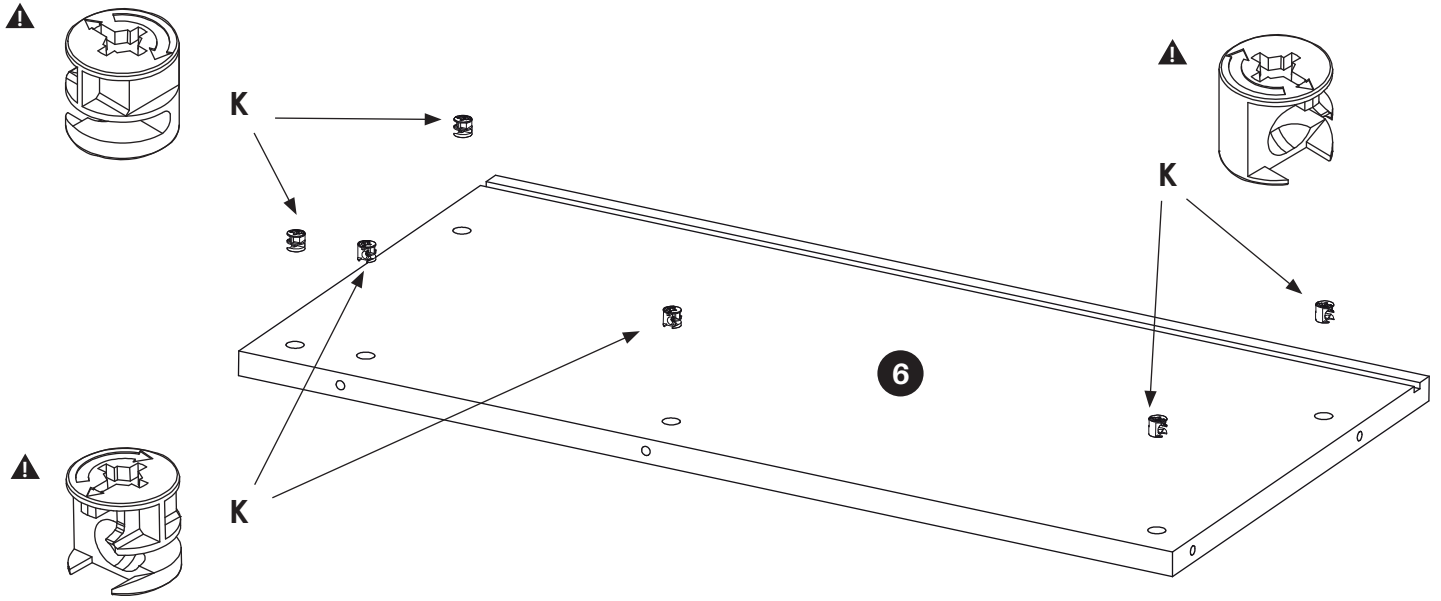

⚠ La flèche des excentriques est orientée vers l'extérieur de la tablette.

# 6.

## OUTILS

tournevis

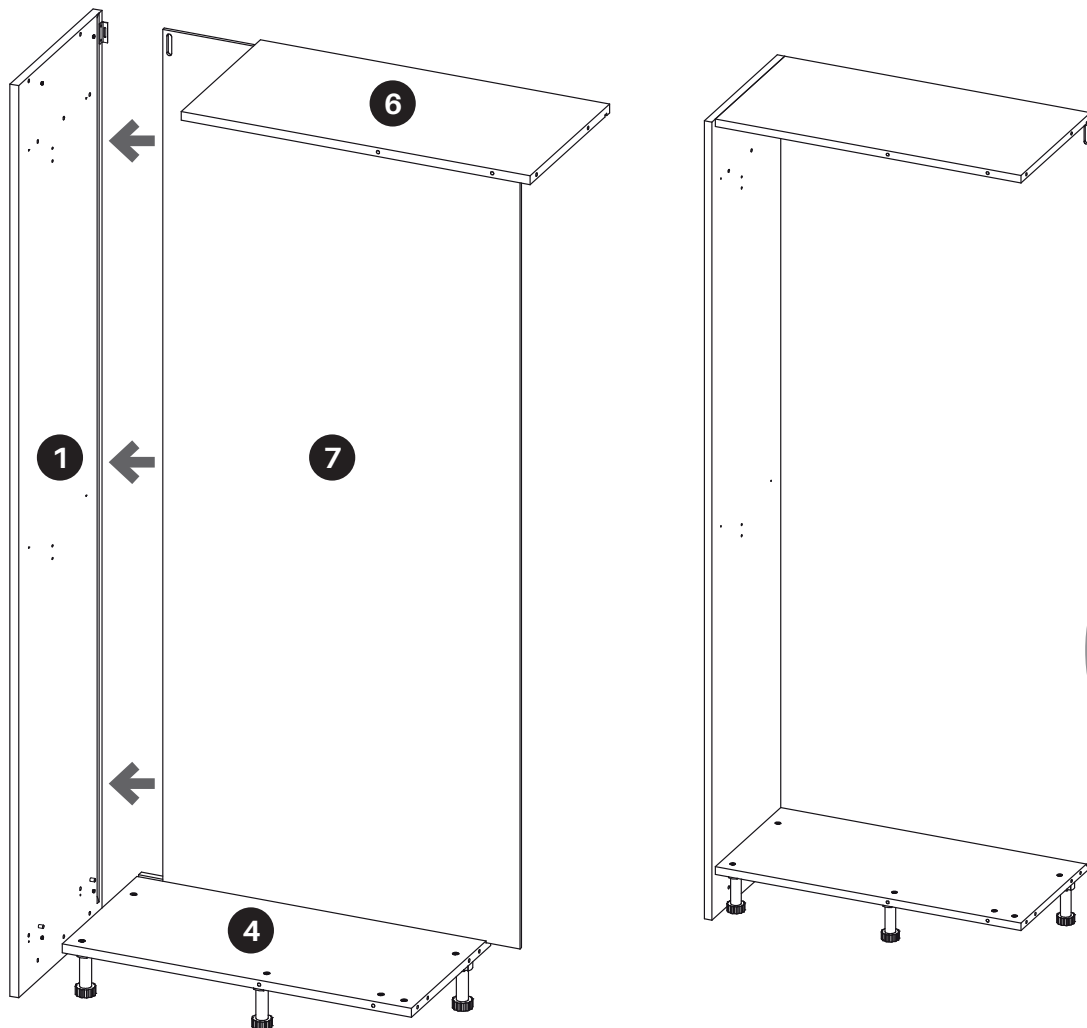

⚠ Serrer les excentriques dans le sens horaire



# 7.

OUTILS	
tournevis	+
maillet	

QUINCAILLERIE		
Sachet n°825		
A	équerre	x1
C	tourillon	x2
D	insert métallique	x4
E	goujon fil métal	x4
F	vis	x2
Sachet n°827		
K	excentrique	x4

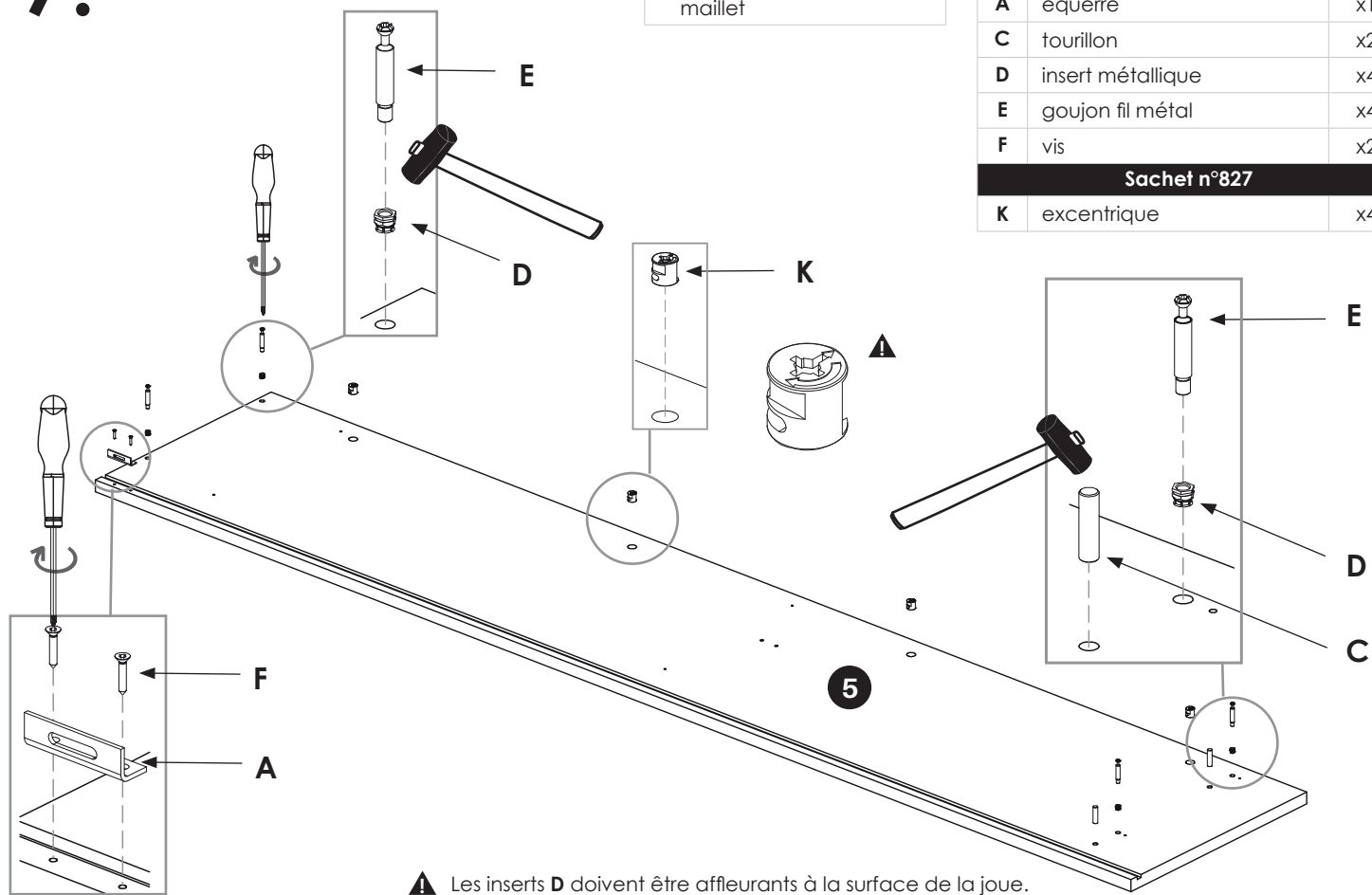

# 8.

OUTILS	
tournevis	+

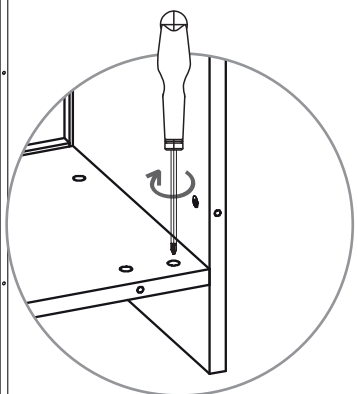
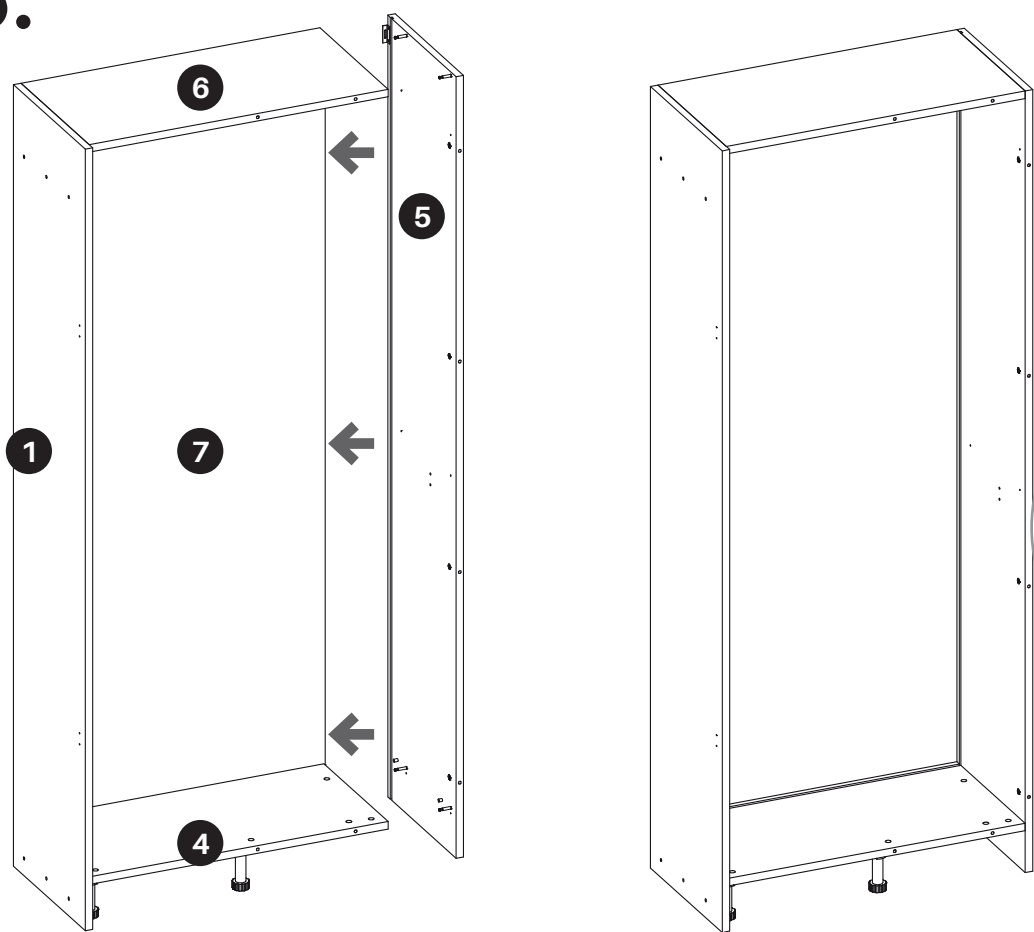

⚠ Serrer les excentriques dans le sens horaire

# 9.

## OUTILS

tournevis

## QUINCAILLERIE

Sachet n°834

R	ferrure mâle	x2
F	vis	x4

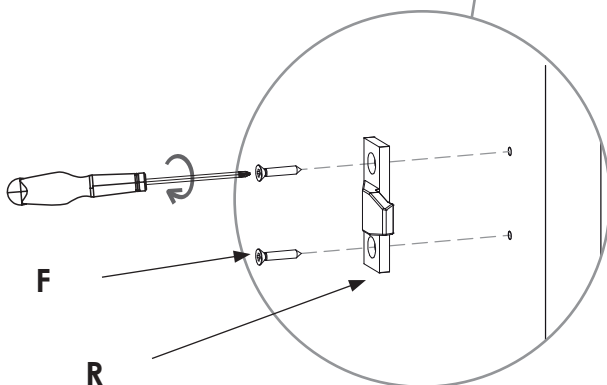
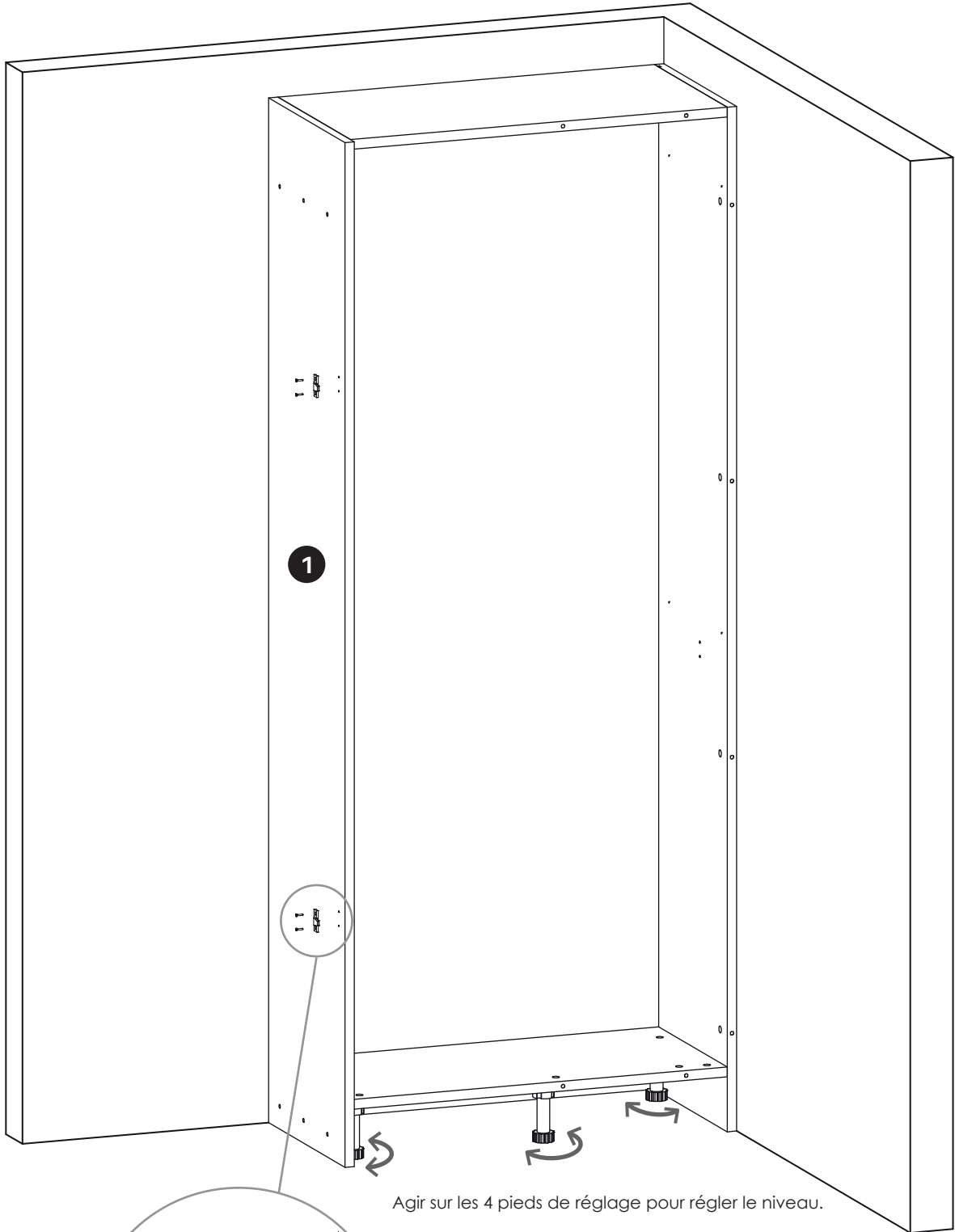

# 10.

Présentation sans tablette haute.

## OUTILS

crayon  
perceuse

## QUINCAILLERIE

**FIXATION MURALE :**  
**VIS ET CHEVILLES NON FOURNIES**

**⚠** Utiliser des vis, rondelles et chevilles adaptées à votre mur.

### ÉTAPE 1

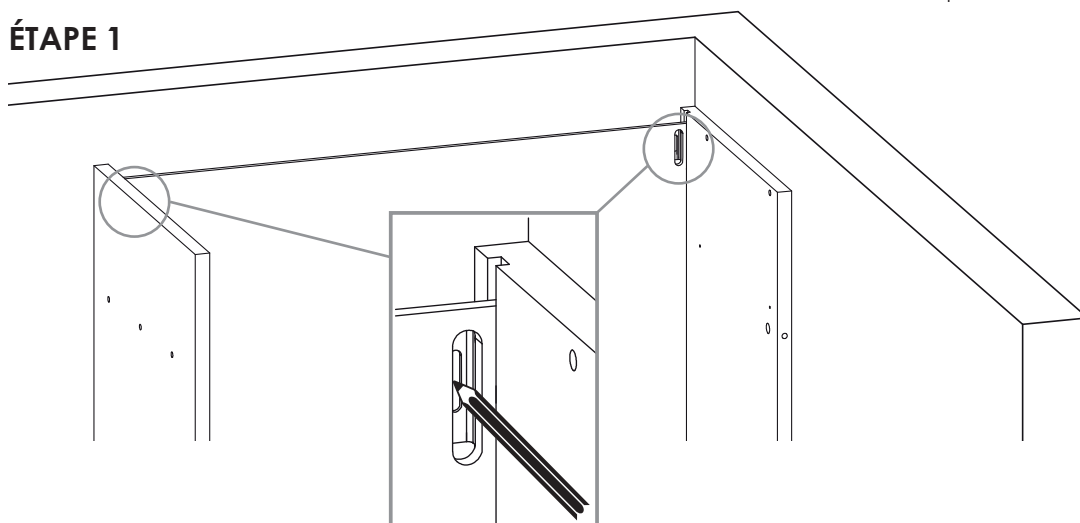

### ÉTAPE 2

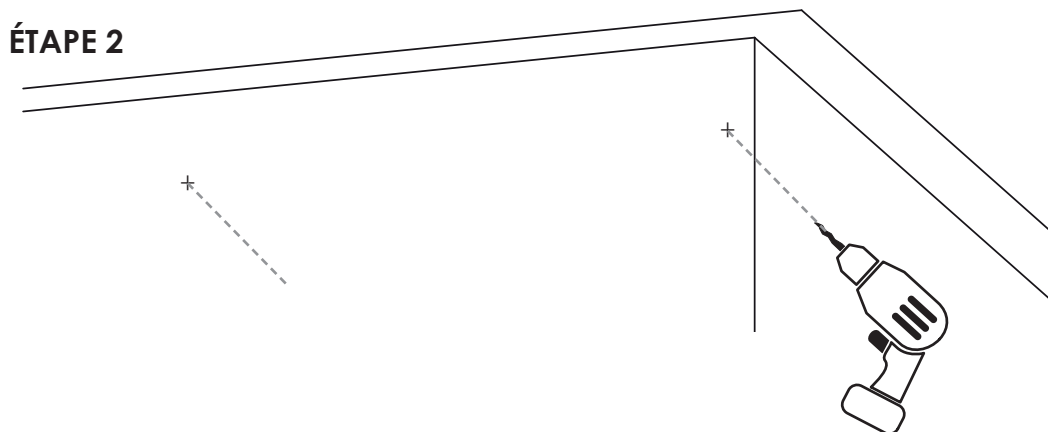

# 11.

Présentation sans tablette haute.

## OUTILS

visseuse

## QUINCAILLERIE

**FIXATION MURALE :**  
**VIS ET CHEVILLES NON FOURNIES**

**⚠** Utiliser des vis, rondelles et chevilles adaptées à votre mur.

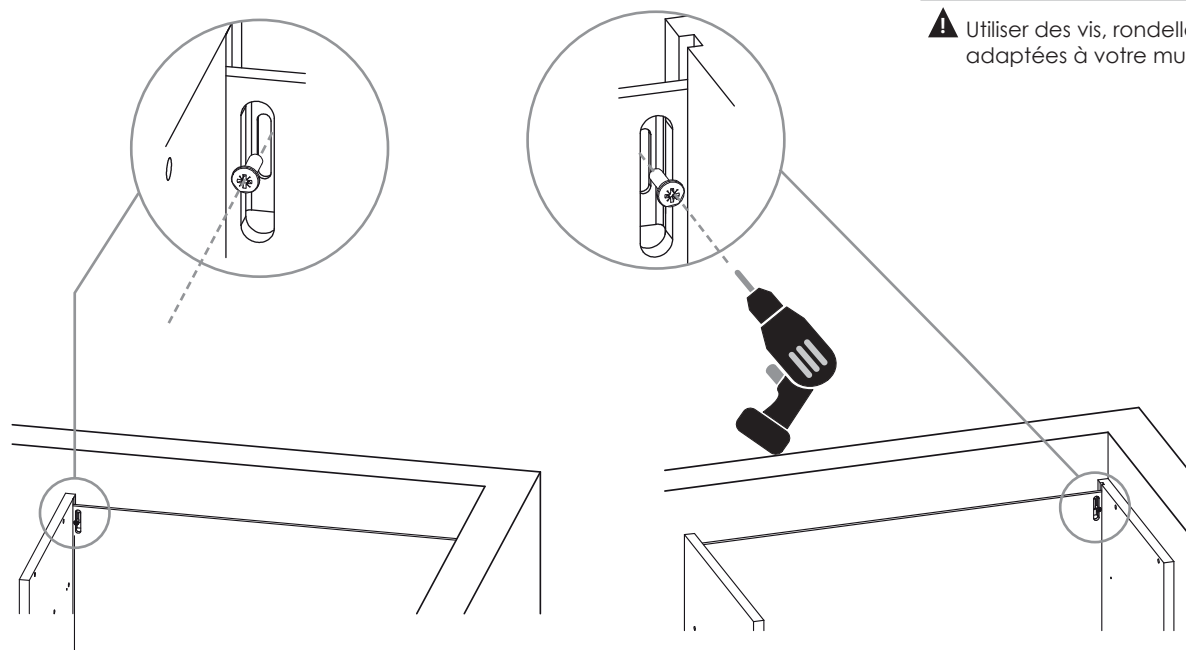

# 12.

x4

17, 18, 19 et 20

### OUTILS

tournevis

### QUINCAILLERIE

Sachet n°846		x4
K	excentrique	x12

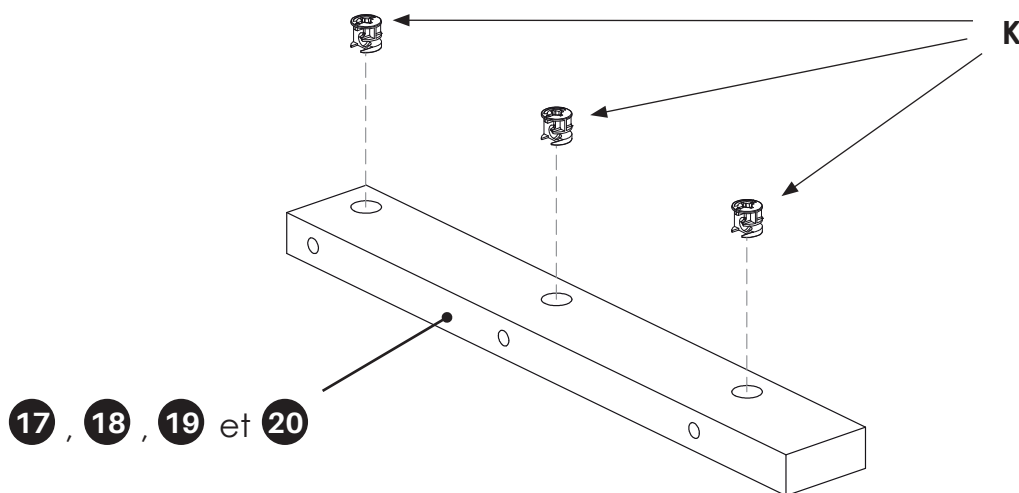

17, 18, 19 et 20

⚠ À l'orientation de la flèche des excentriques.

# 13.

### OUTILS

tournevis



maillet

### QUINCAILLERIE

Sachet n°846		x2
D	insert métallique	x6
E	goujon fil métal	x6
Sachet n°834		
R	ferrure mâle	x3
F	vis	x6

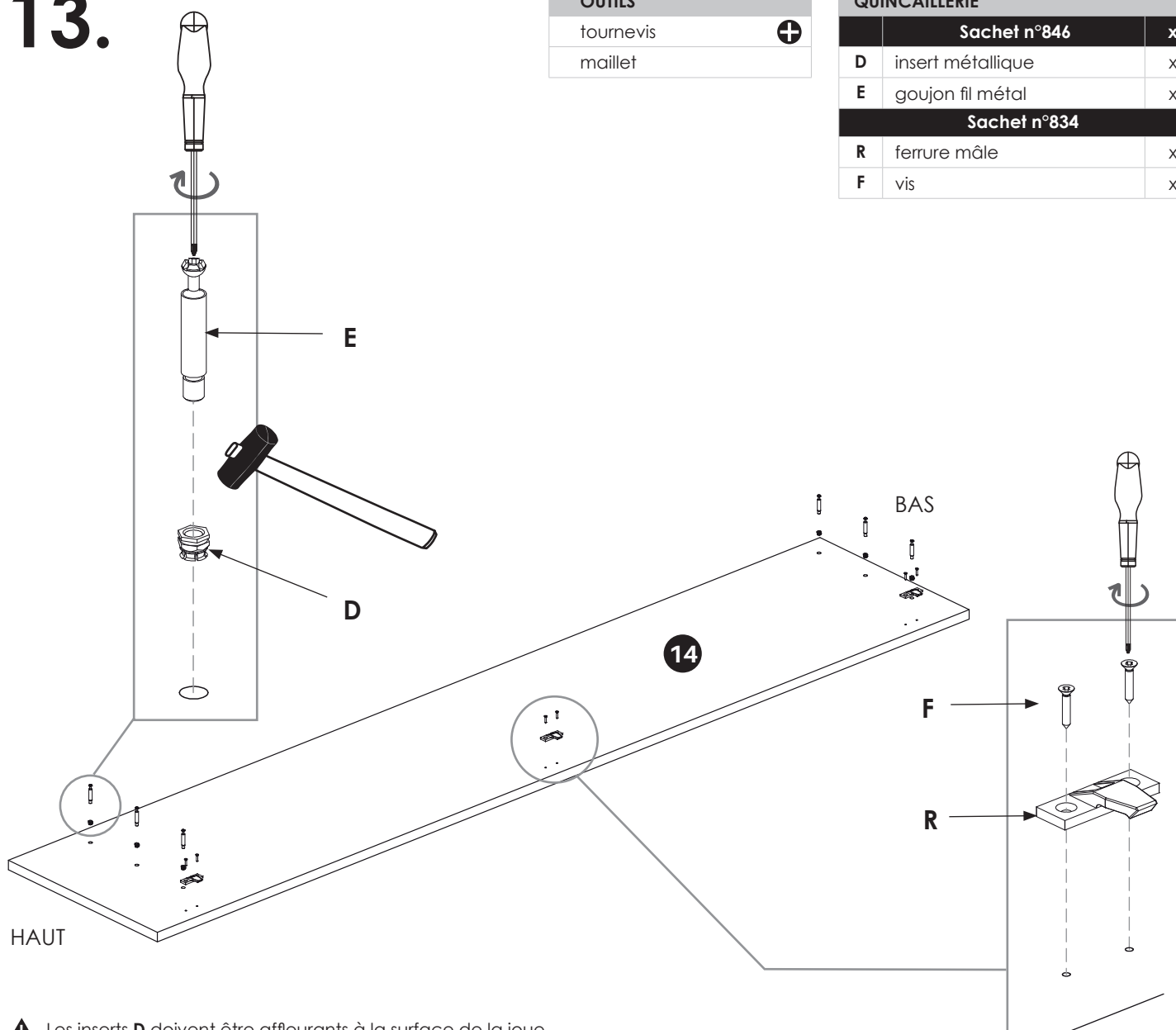

⚠ Les inserts D doivent être affleurants à la surface de la joue.

# 14.

## OUTILS

tournevis



### ÉTAPE 1

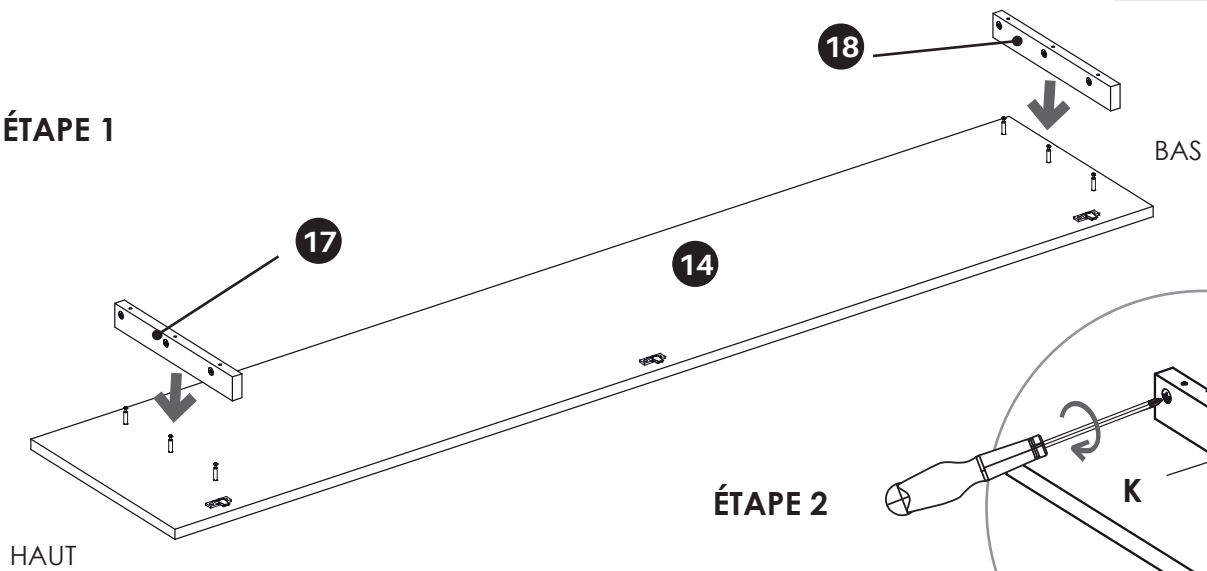

### ÉTAPE 2

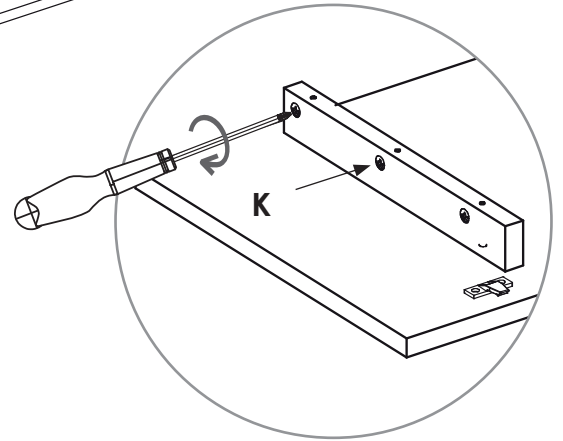

# 15.

## OUTILS

clé 6 pans

## QUINCAILLERIE

	<b>Sachet n°846</b>	<b>x2</b>
<b>S</b>	vis	x6

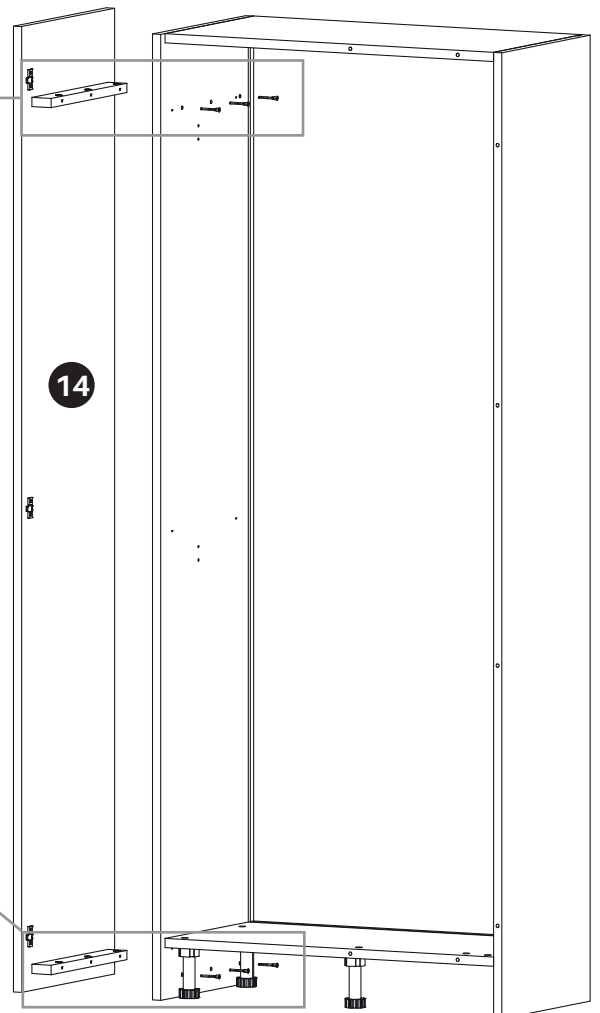
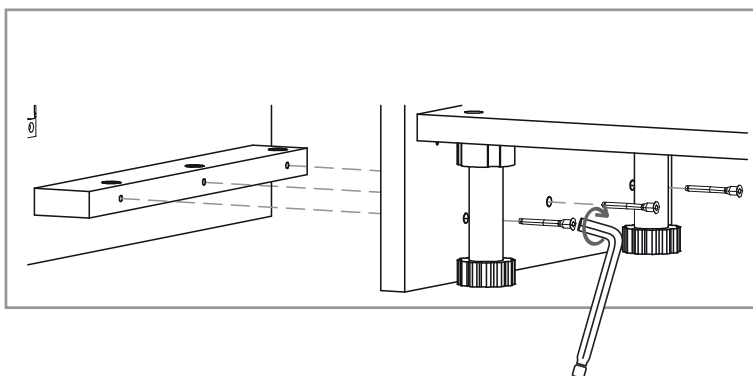
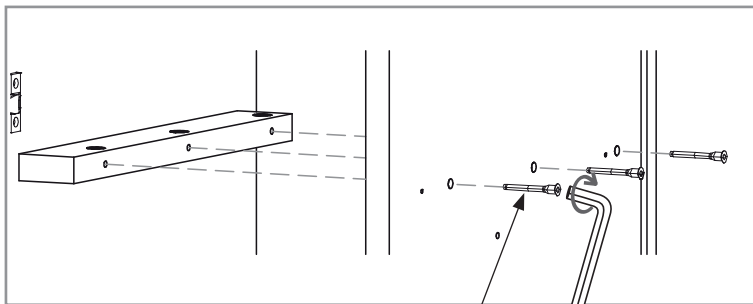

# 16.

**OUTILS**

tournevis

**QUINCAILLERIE****Sachet n°804**

M goujon

x4

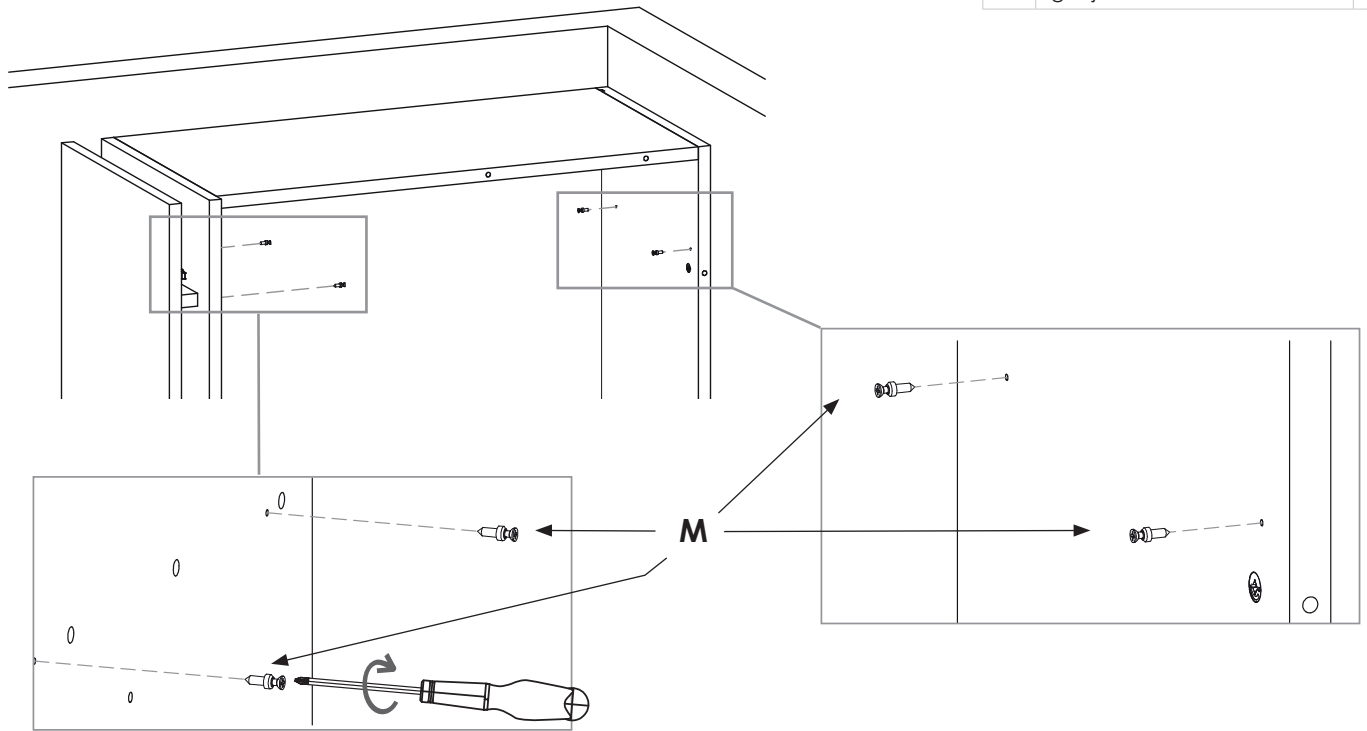

# 17.

**OUTILS**

tournevis

**QUINCAILLERIE****Sachet n°848**

x4

T goujon double

x8

**⚠** Pensez à retirer les circlips sur les goujons double avant utilisation.

Le goujon double peut être inséré dans n'importe quel sens.

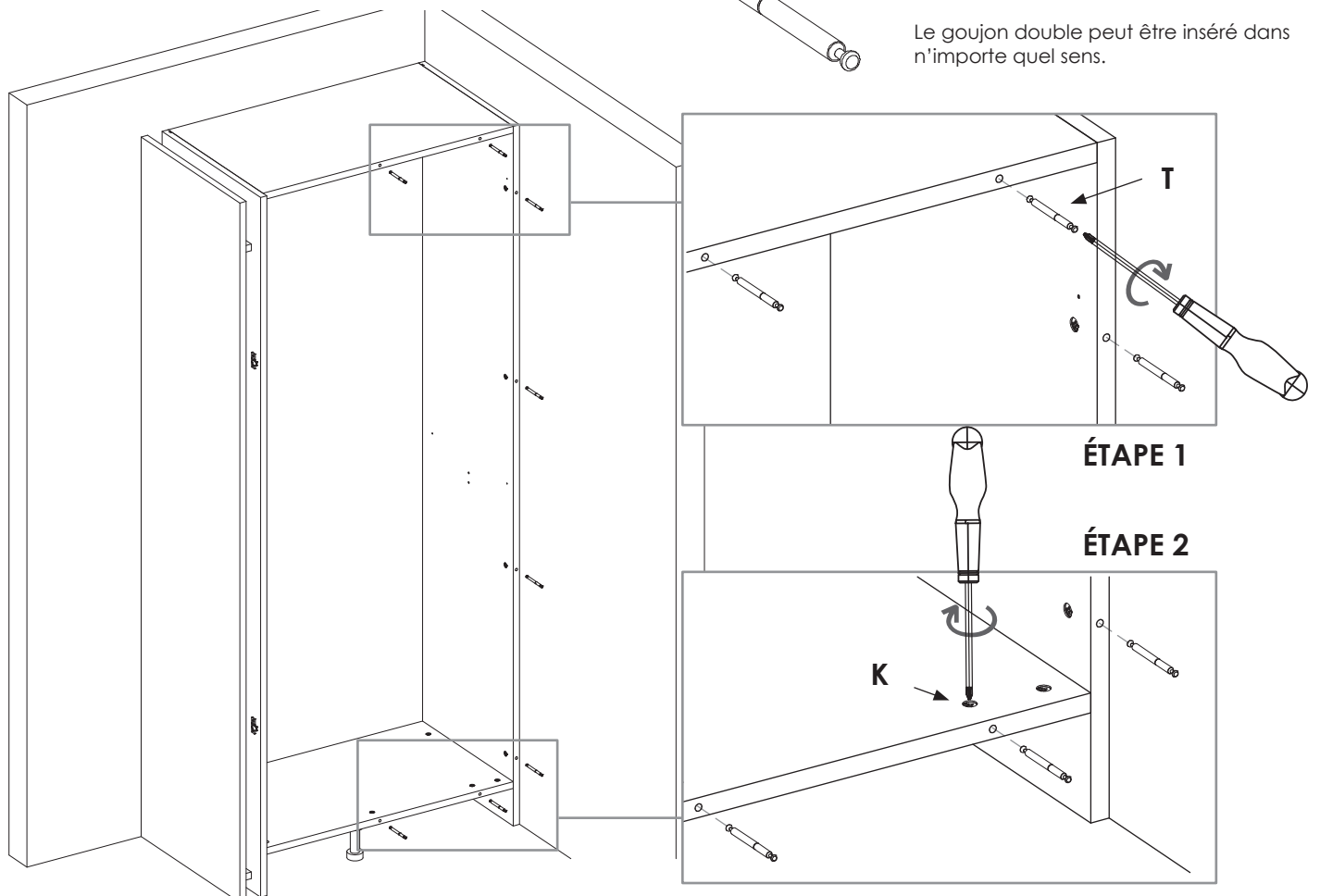

# 18.



QUINCAILLERIE		
Sachet n°827		
K	excentrique	x8

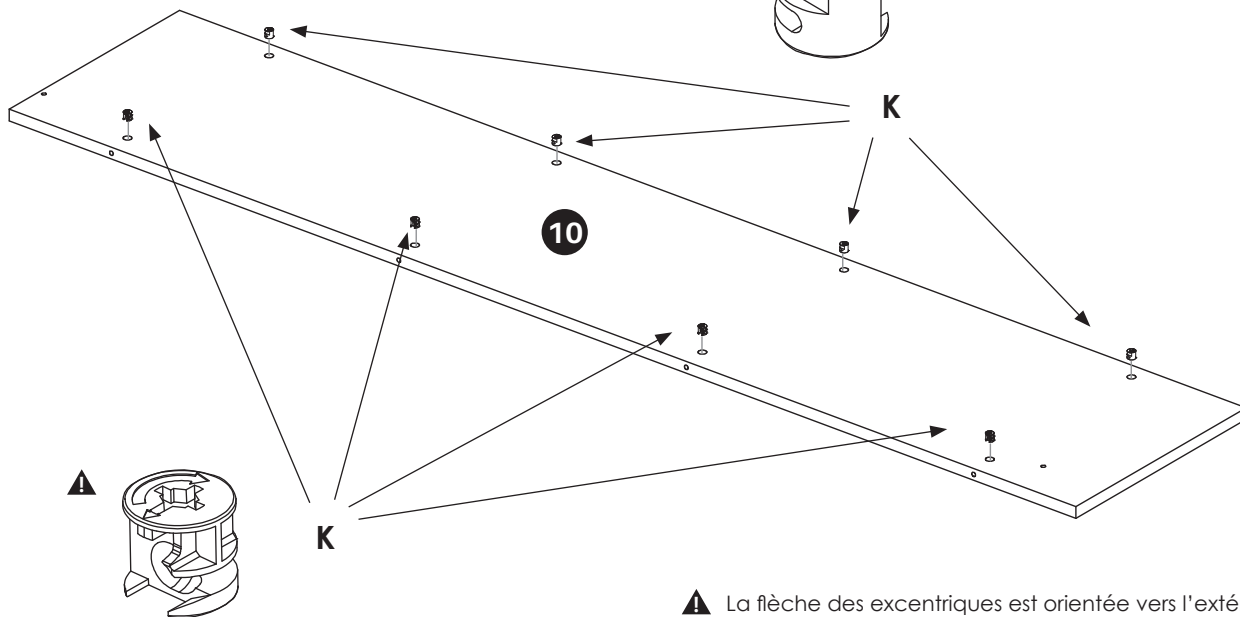

⚠ La flèche des excentriques est orientée vers l'extérieur de la joue.

# 19.

### OUTILS

tournevis	+
maillet	

### QUINCAILLERIE

Sachet n°849		
D	insert métallique	x8
E	goujon fil métal	x8
C	tourillon	x6

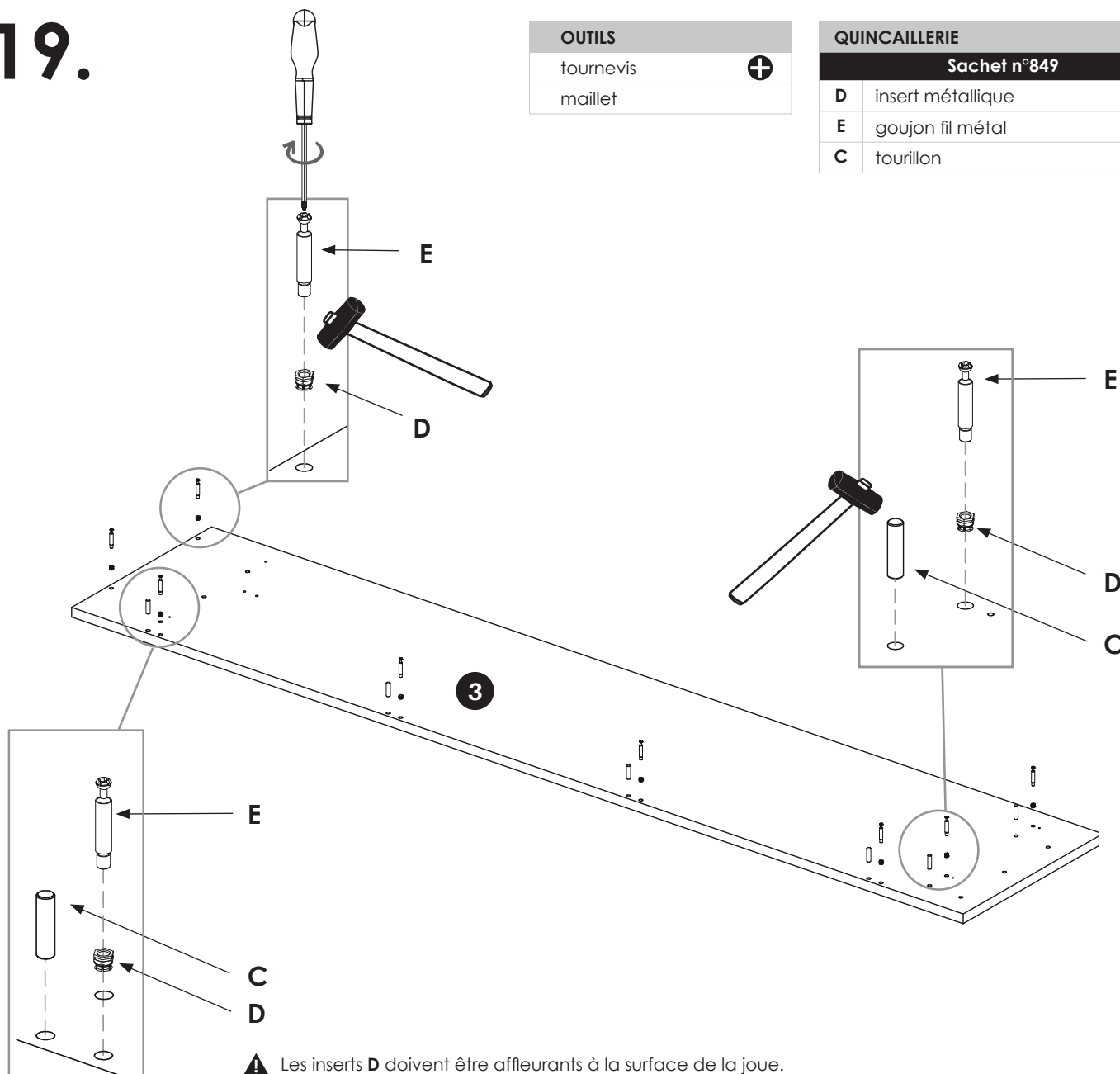

⚠ Les inserts D doivent être affleurants à la surface de la joue.

# 20.

OUTILS

tournevis



ÉTAPE 1

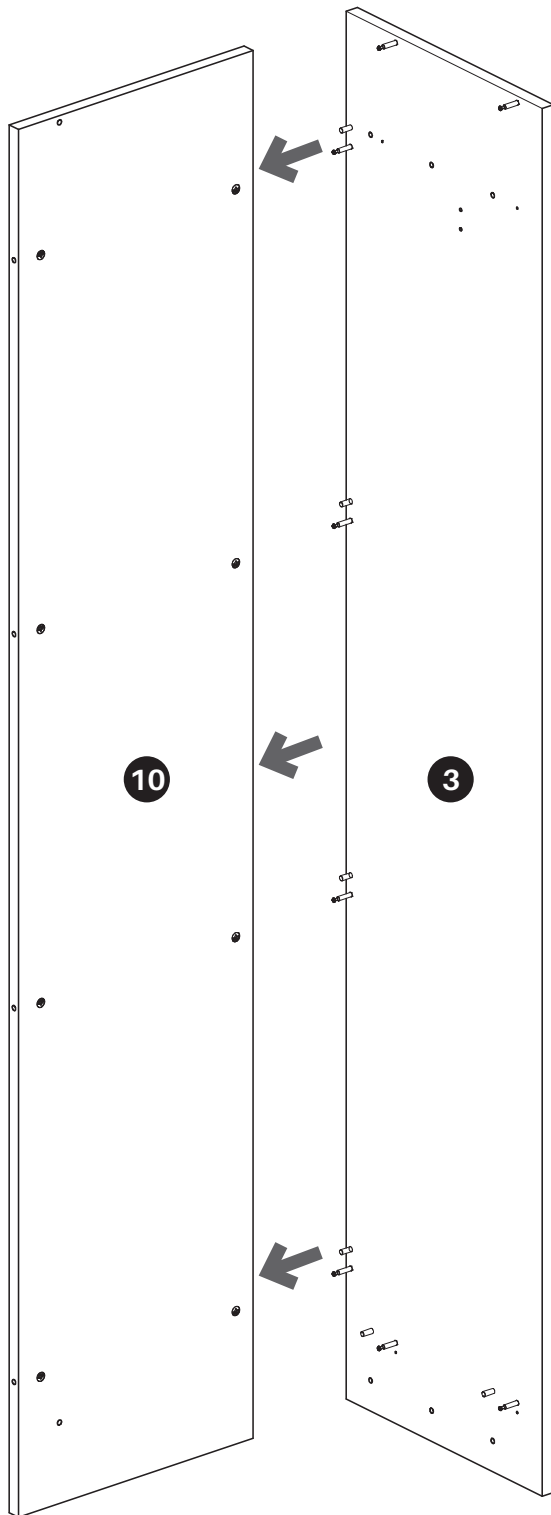

ÉTAPE 2

K

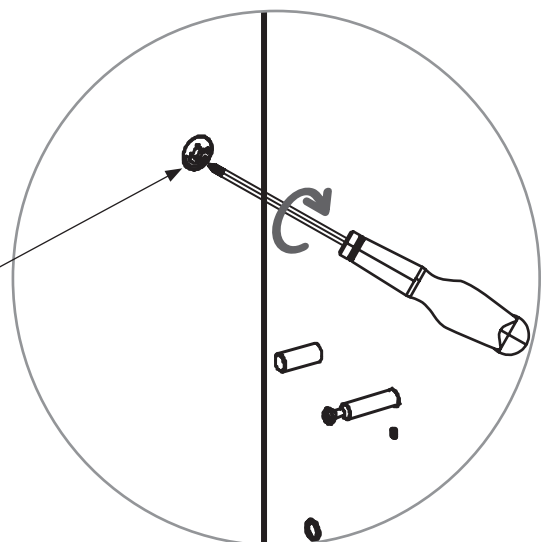



# 21.

## OUTILS

tournevis	+
maillet	

## QUINCAILLERIE

Sachet n°846		x2
D	insert métallique	x6
E	goujon fil métal	x6
Sachet n°834		
R	ferrure mâle	x2
F	vis	x4

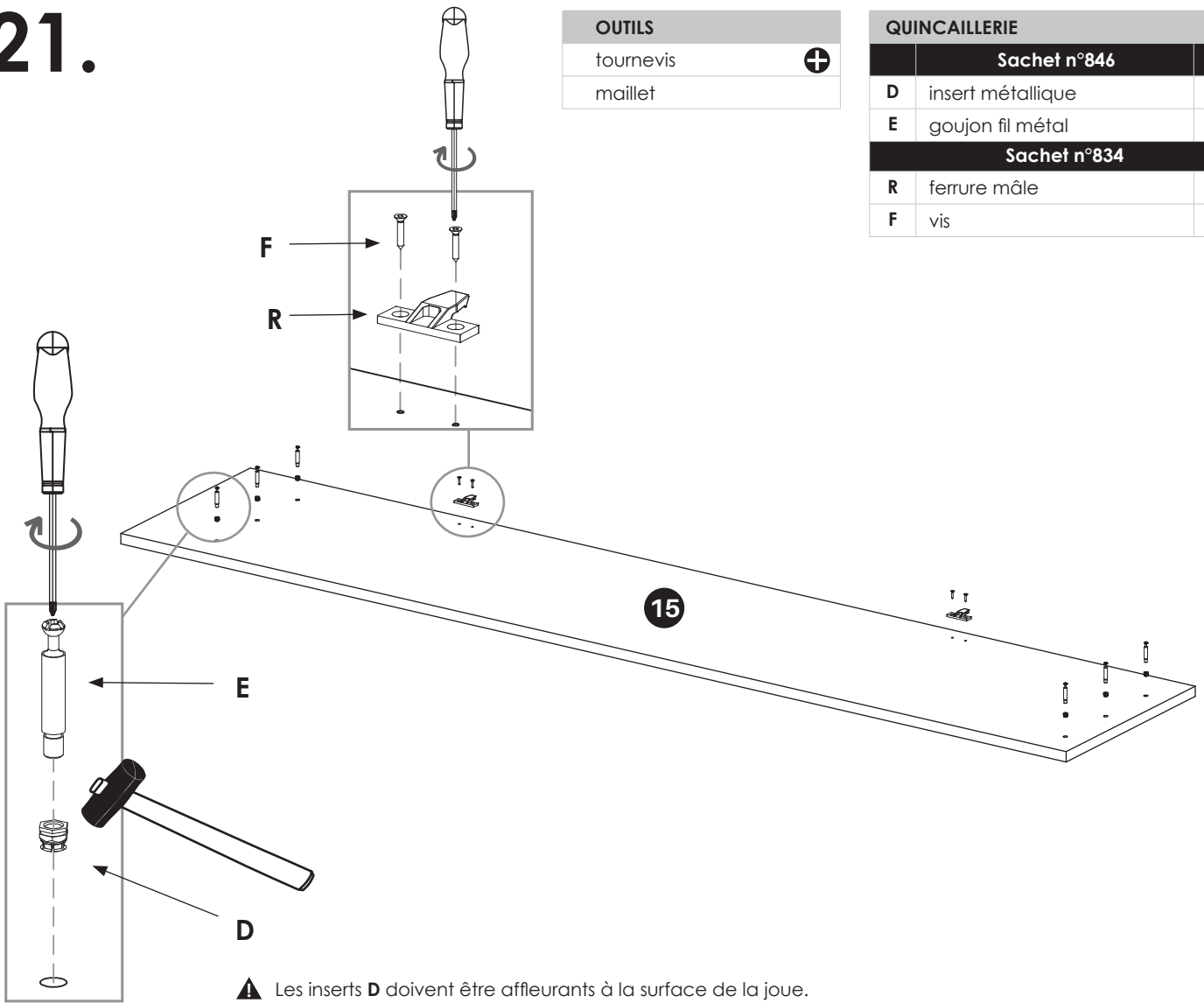

# 22.

## OUTILS

tournevis	+
-----------	---

### ÉTAPE 1

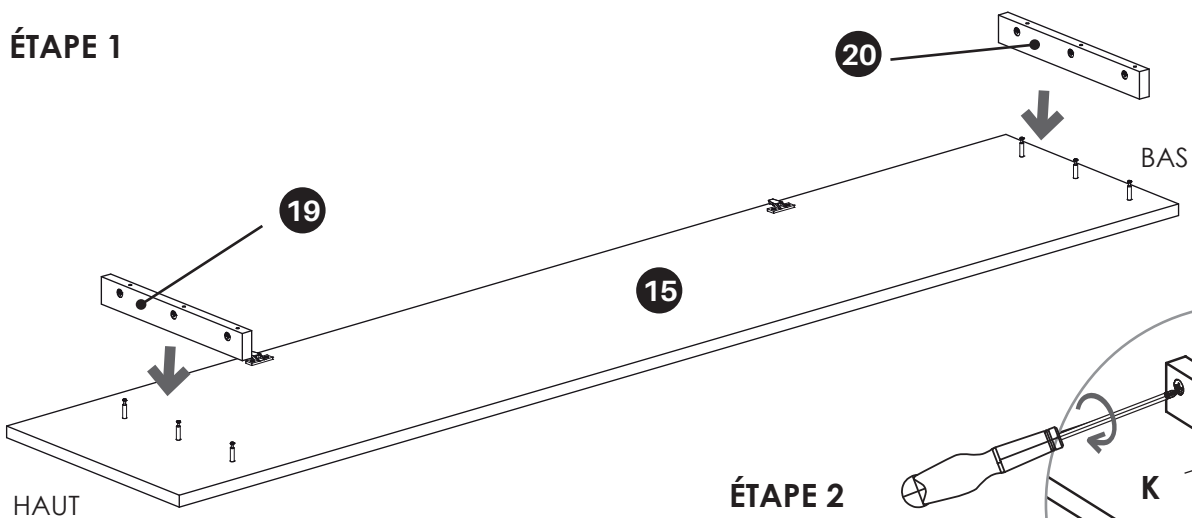

# 23.

## OUTILS

clé 6 pans

tournevis



## QUINCAILLERIE

Sachet n°846		x2
S	vis	x6
Sachet n°847		
M	goujon	x2

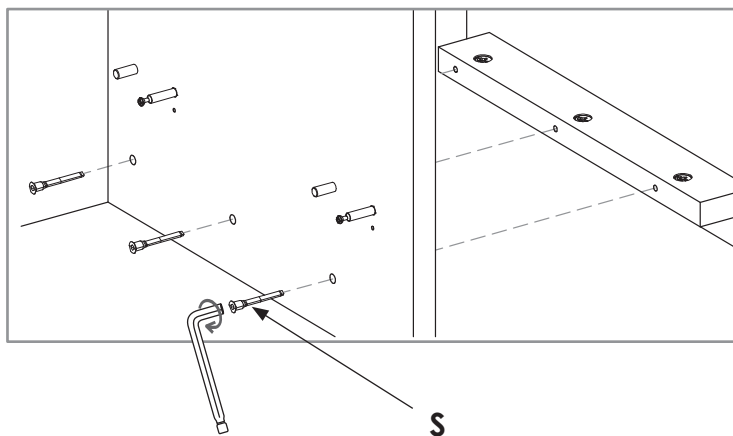
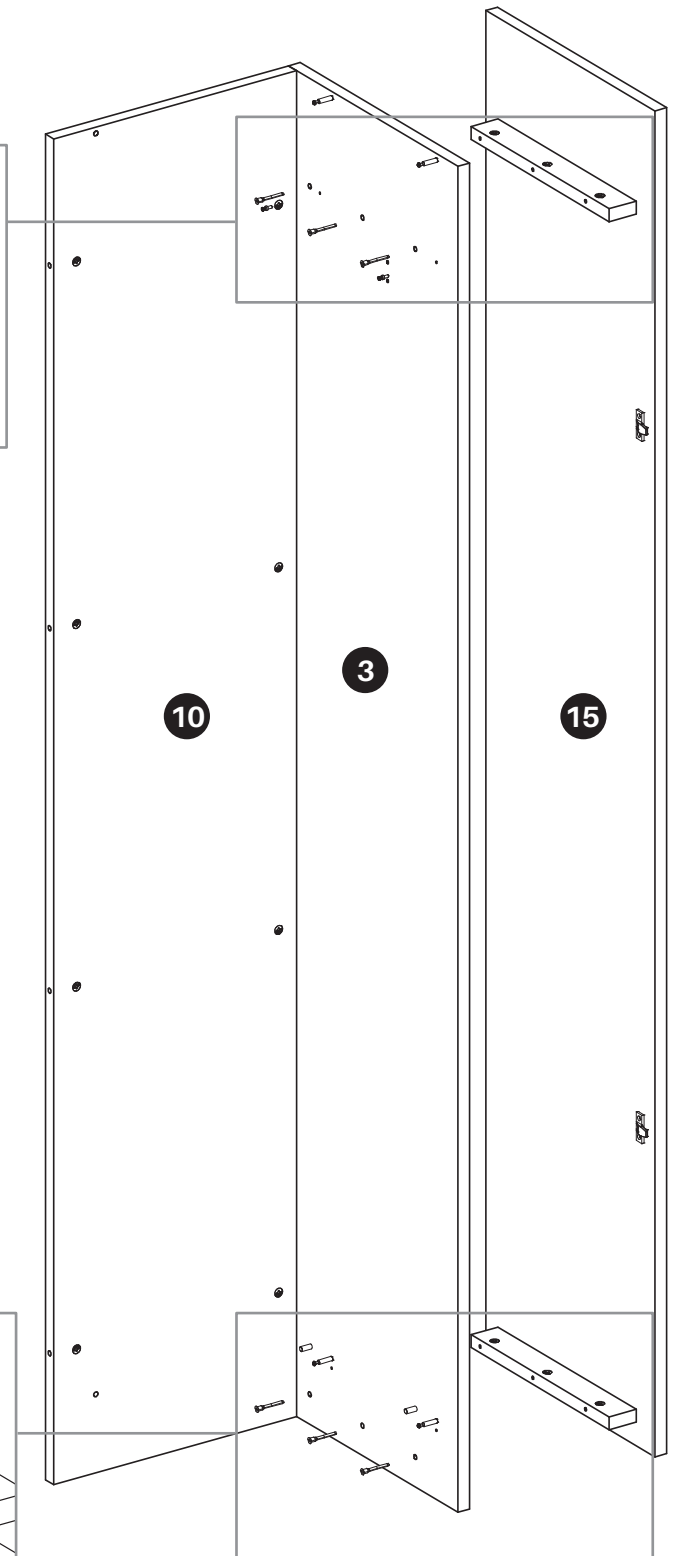
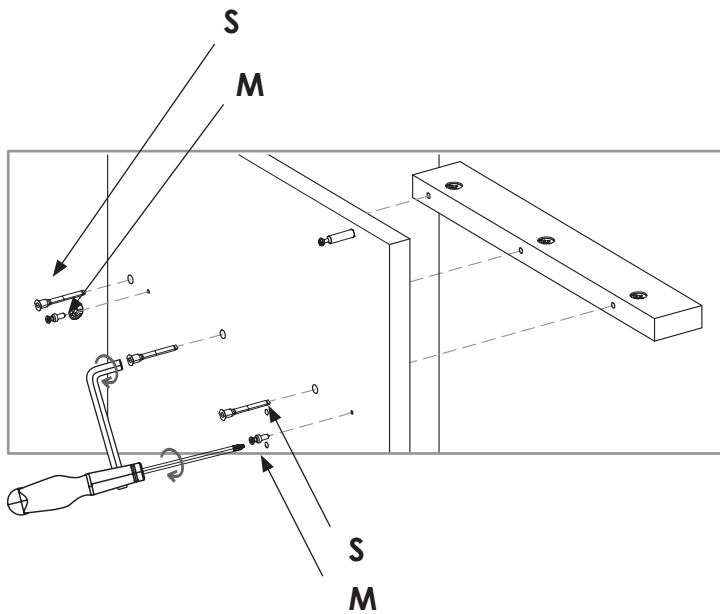

# 24. Montage de la tablette semi-fixe.

## OUTILS

maillet

tournevis



## QUINCAILLERIE

### Sachet n°847

C tourillon x2

T goujon double x2

L boîtier x2

### Sachet n°804

L boîtier x4

### Sachet n°827

K excentrique x4

## ÉTAPE 1

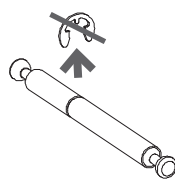

⚠ Pensez à retirer les circlips sur les goujons double avant utilisation. Le goujon double peut être inséré dans n'importe quel sens.

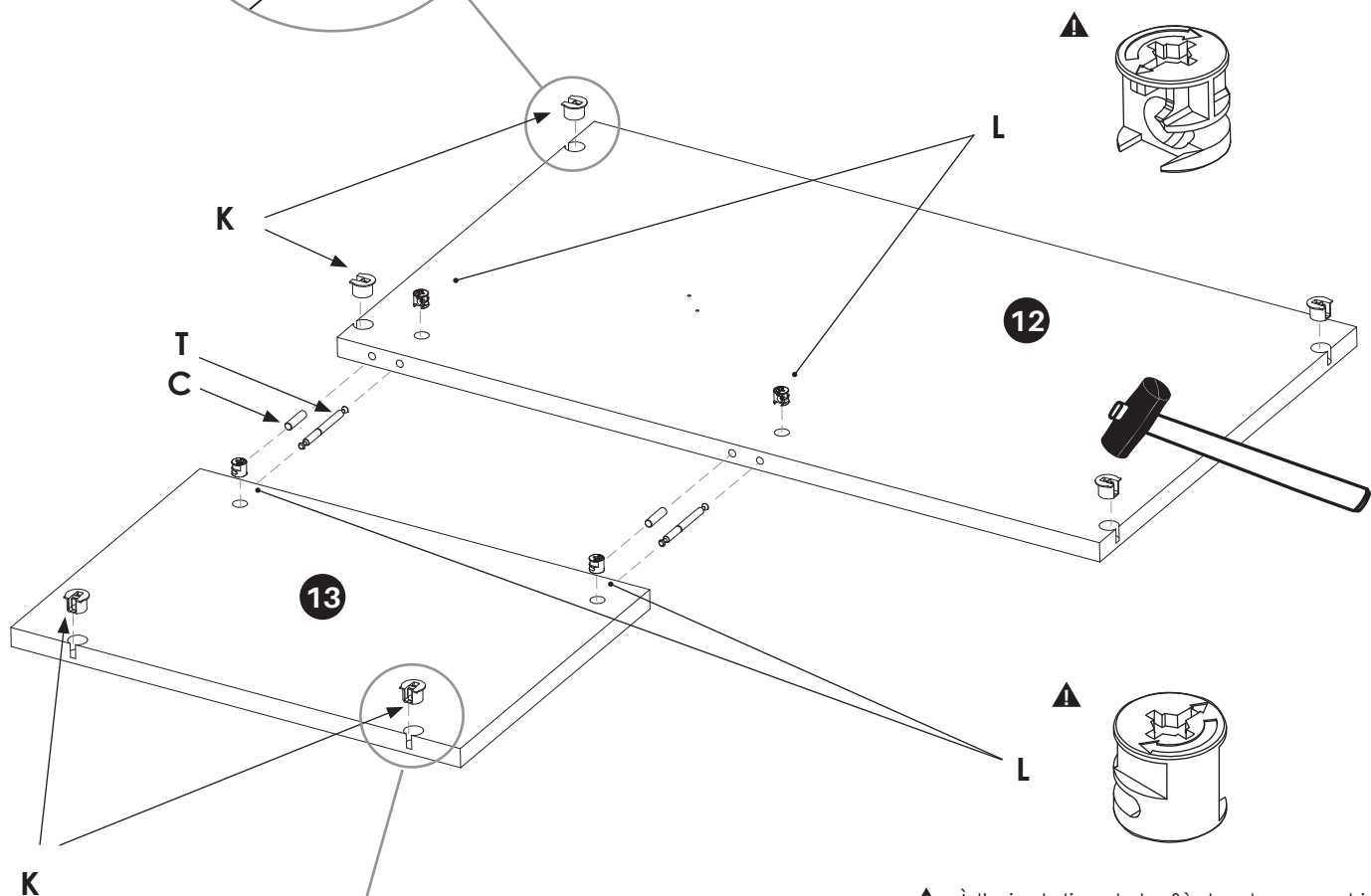

⚠ À l'orientation de la flèche des excentriques.

## ÉTAPE 2

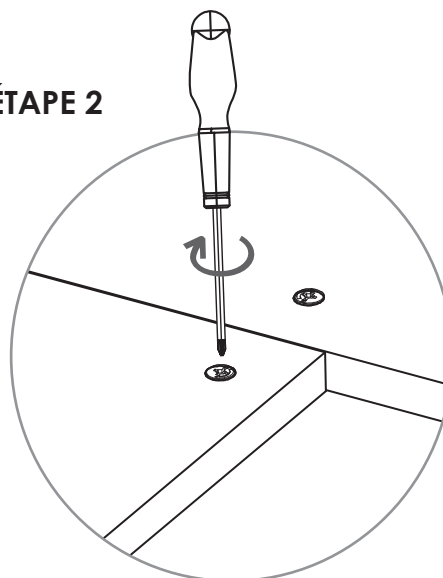

# 25.

## QUINCAILLERIE

Sachet n°827

K	excentrique	x4
---	-------------	----

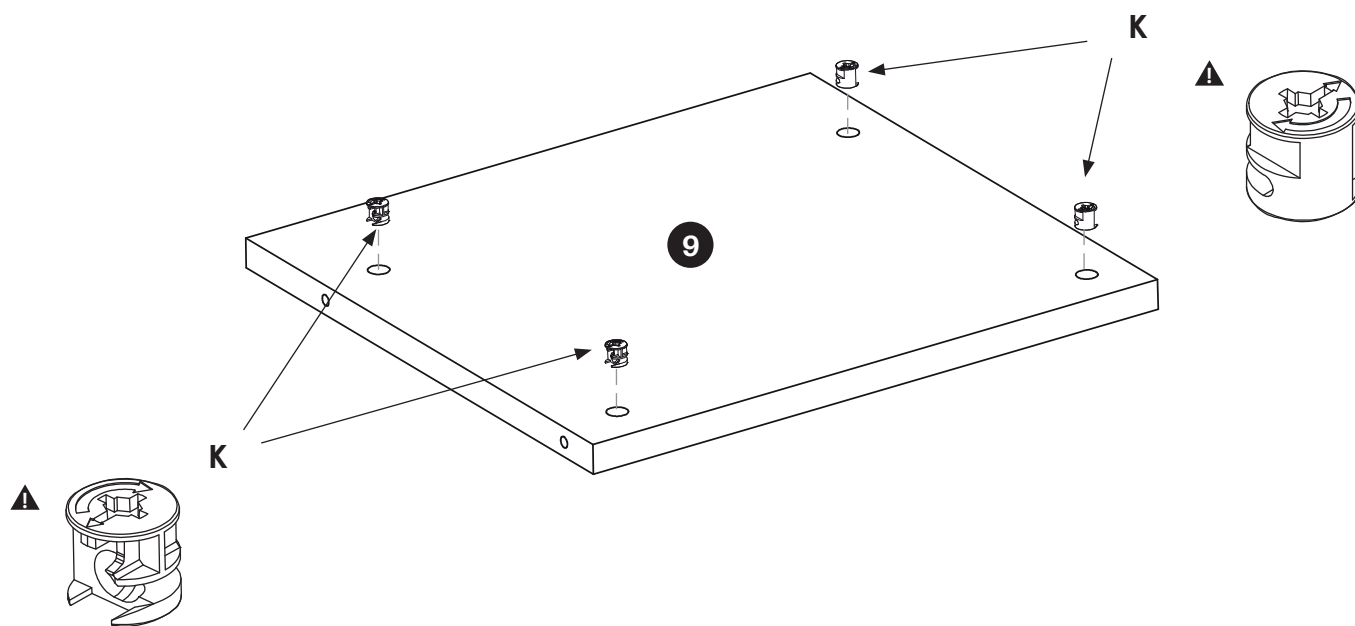

⚠ La flèche des excentriques est orientée vers l'extérieur de la tablette.

# 26. ↻

## OUTILS

tournevis



## QUINCAILLERIE

Sachet n°826

I	embase	x4
J	piéd	x4
F	vis	x16

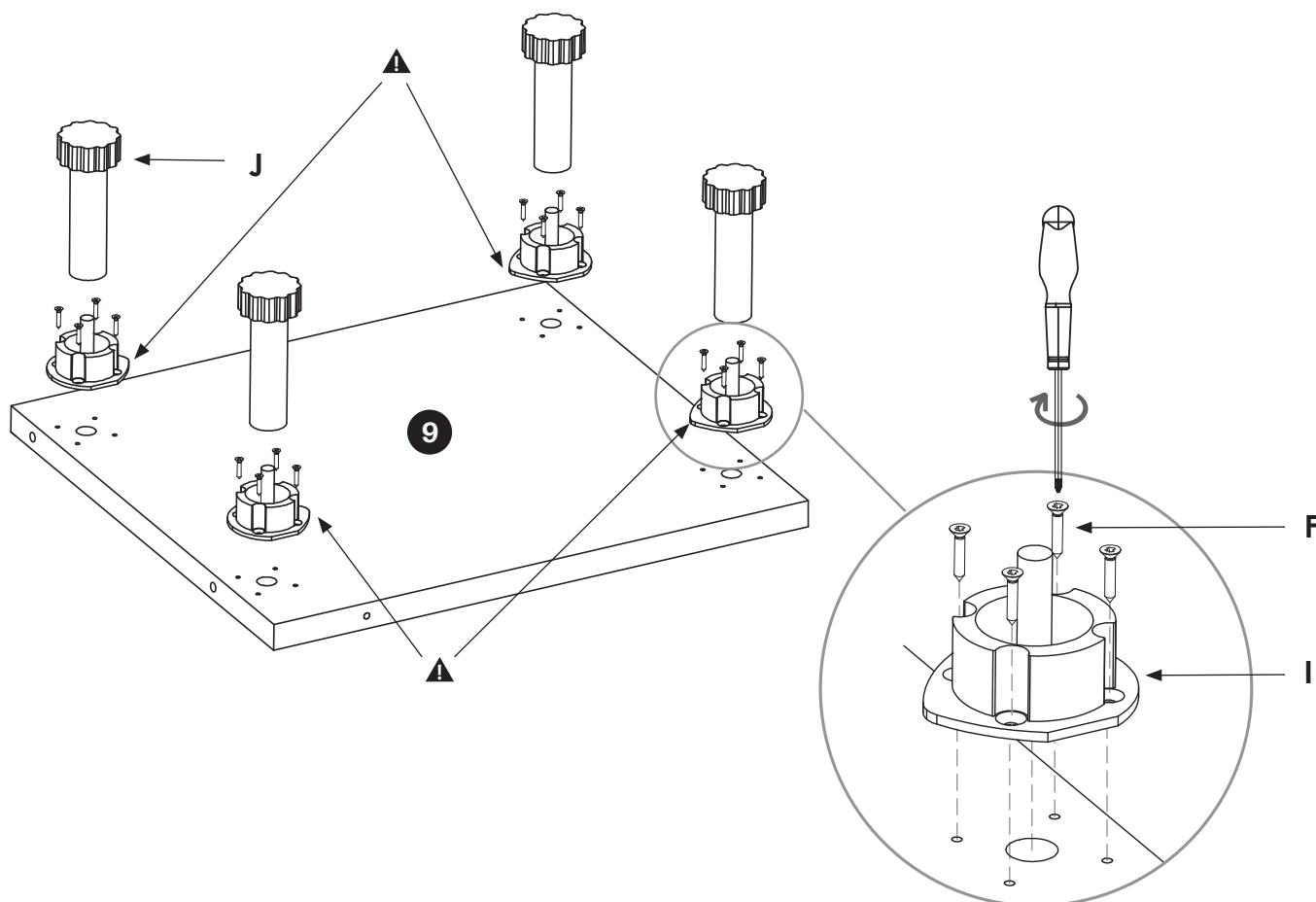

⚠ Les embases doivent être positionnées avec la pointe vers l'intérieur de la tablette.

# 27.

**QUINCAILLERIE**

Sachet n°827

K	excentrique	x4
---	-------------	----

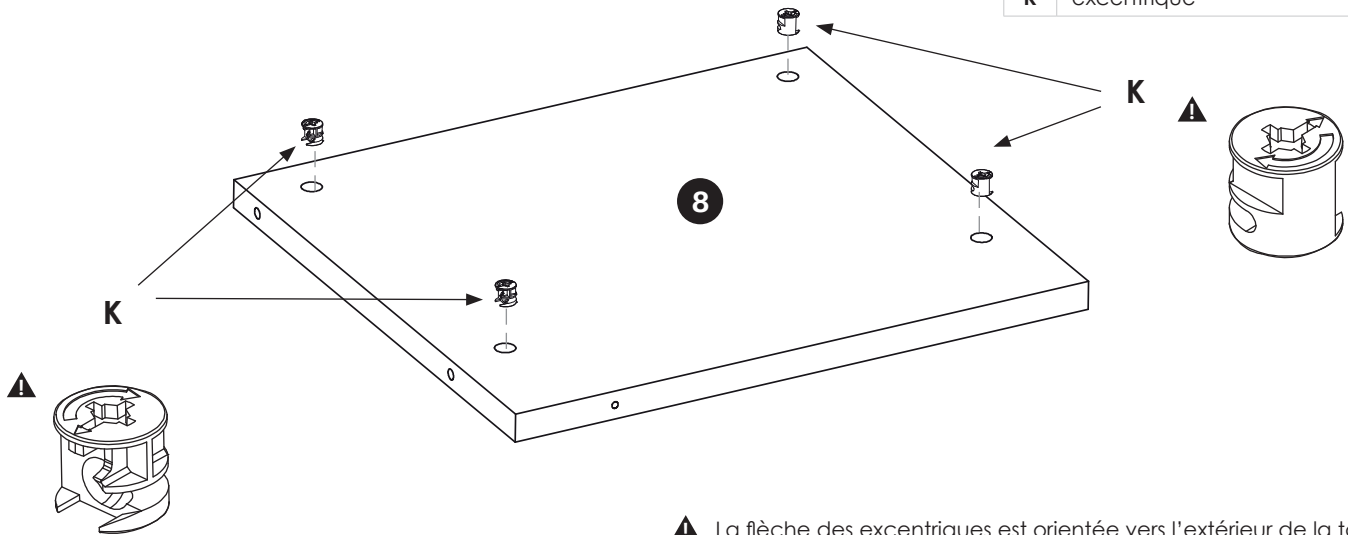

⚠ La flèche des excentriques est orientée vers l'extérieur de la tablette.

# 28.

Réaliser cette étape à proximité de l'ensemble préalablement monté, afin de limiter les déplacements à l'étape 29.

**OUTILS**

tournevis	+
clé 6 pans	

**QUINCAILLERIE**

Sachet n°832

S	vis	x2
---	-----	----

Dans le sachet 832, il restera 4 vis non utilisées.

**ÉTAPE 1**

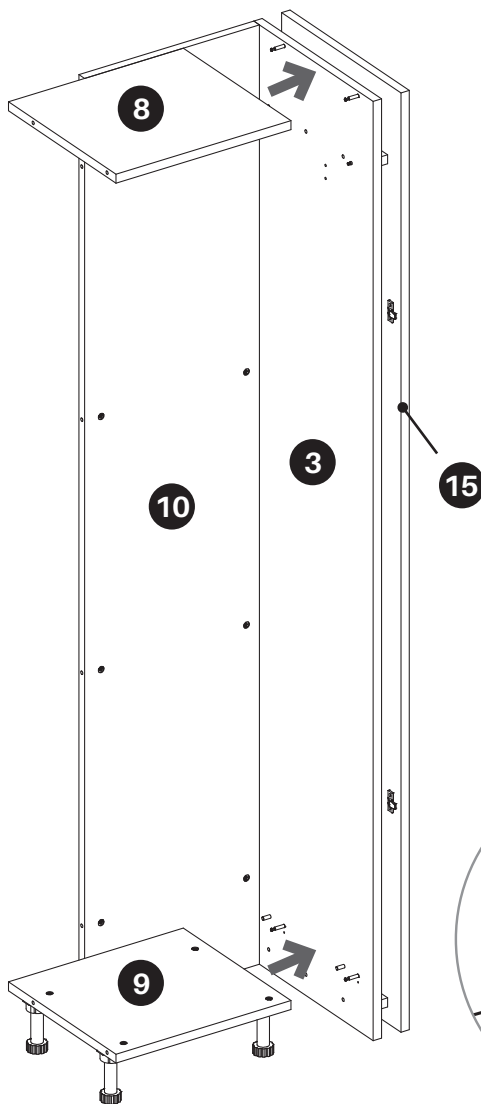

VUE DE FACE

**ÉTAPE 2**

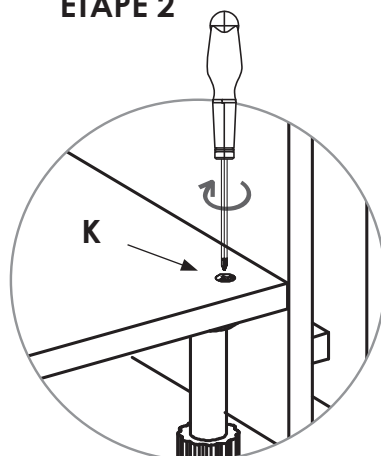

**ÉTAPE 3**

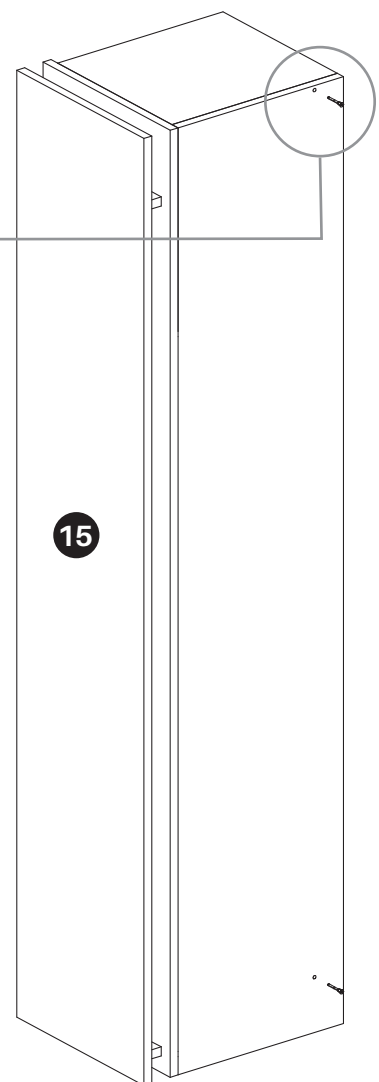

VUE DE DOS

# 29.

OUTILS

tournevis



## ÉTAPE 1

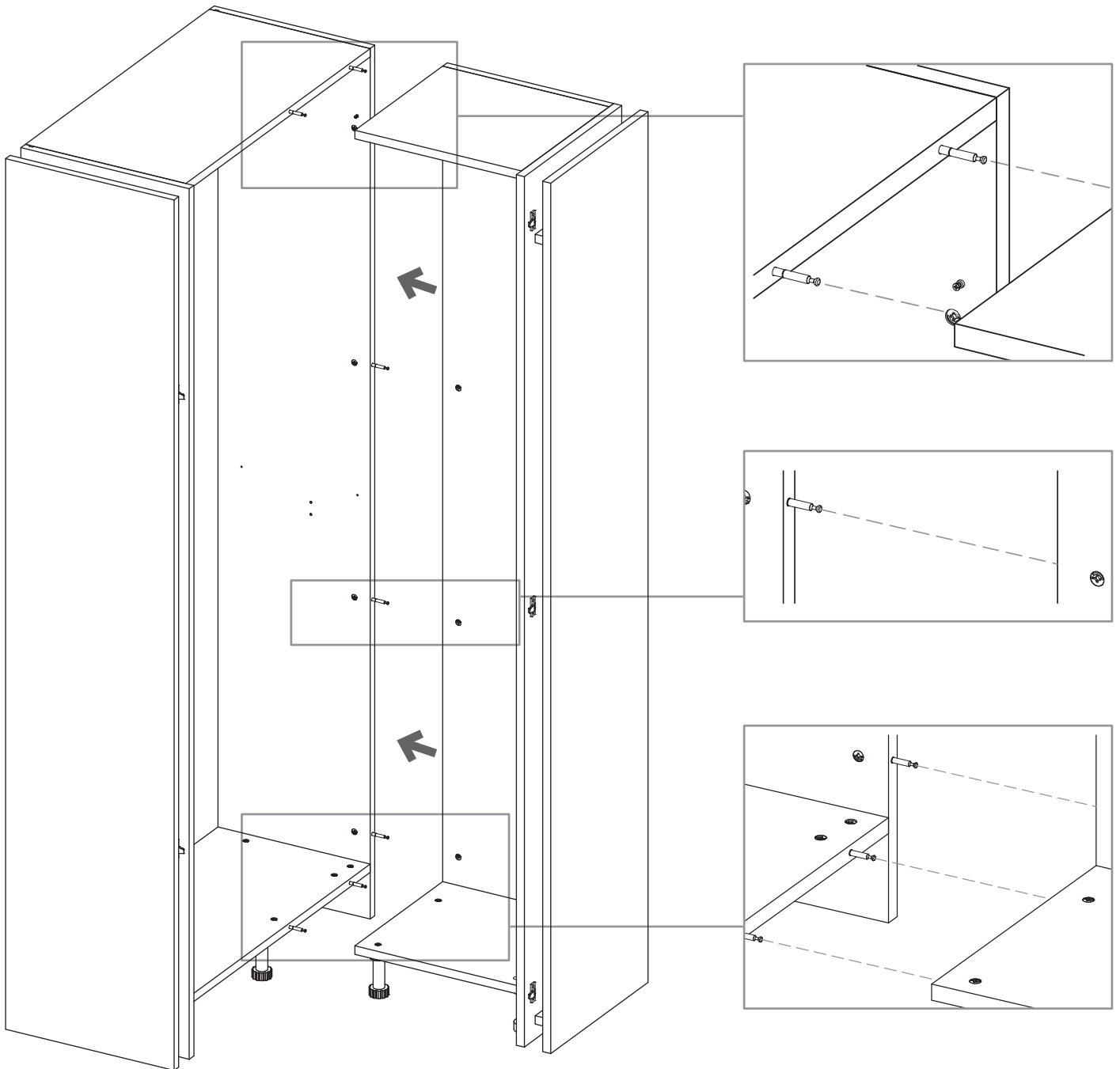

## ÉTAPE 2

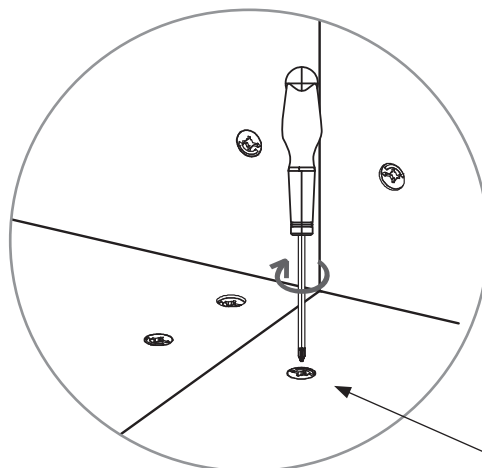

K

# 30. Installation de la tablette semi-fixe.

## ÉTAPE 1

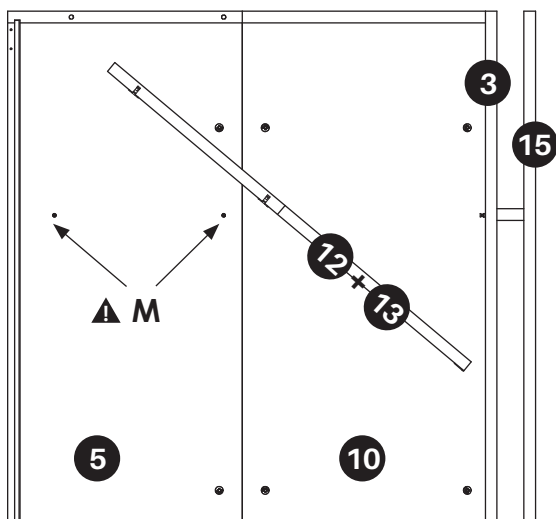

## ÉTAPE 2

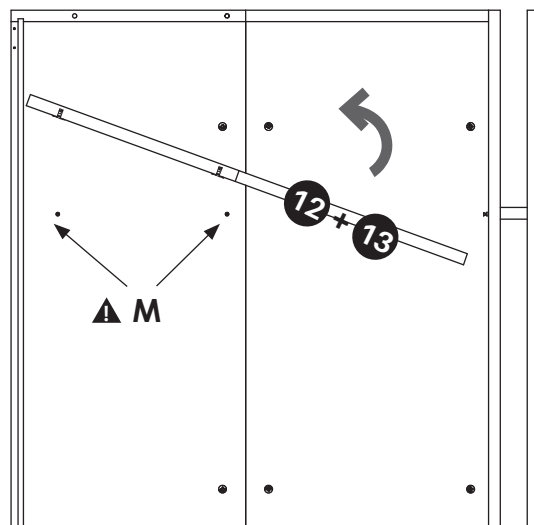

▲ Insérer la tablette semi-fixe pour qu'elle passe au dessus des goujons M.

## ÉTAPE 3

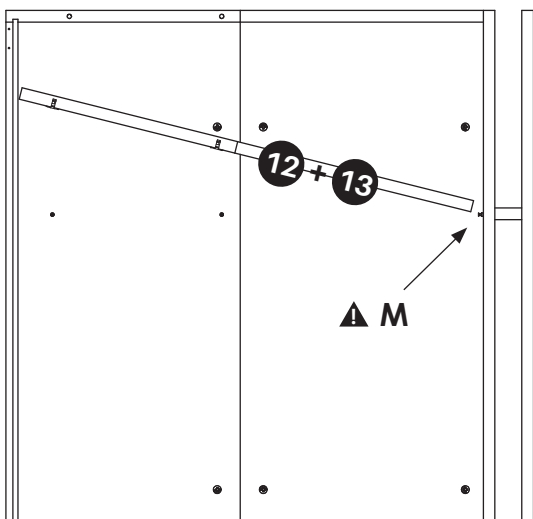

## ÉTAPE 4

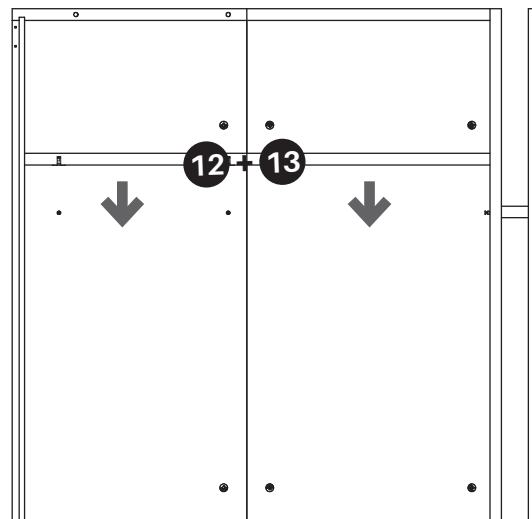

▲ Insérer la tablette semi-fixe pour qu'elle passe au dessus des goujons M.

## ÉTAPE 5

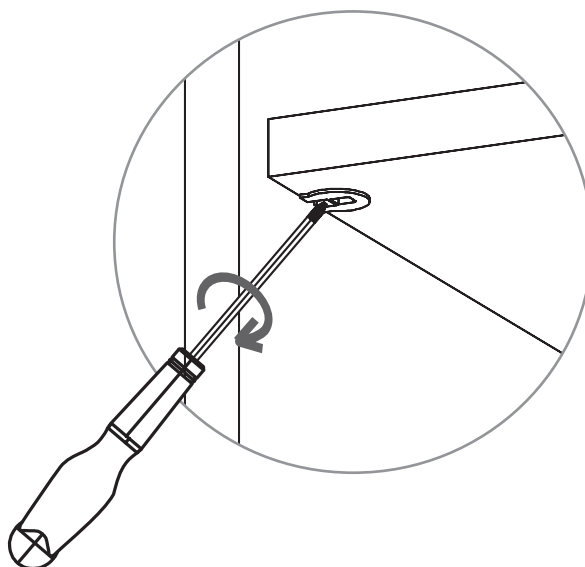

# 31.

## OUTILS

tournevis



## QUINCAILLERIE

	Sachet n°801	x2
G	clip de plinthe	x4
H	support clip de plinthe	x4
F	vis	x8

### ÉTAPE 1

x2

23 et 24

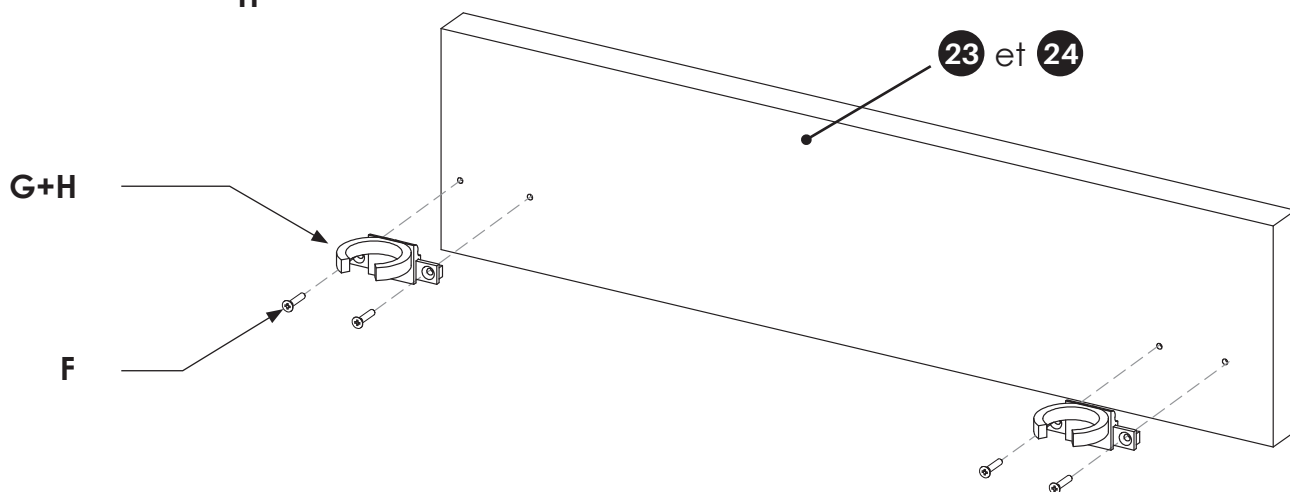
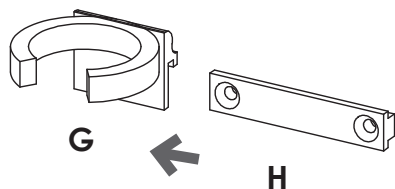

### ÉTAPE 2

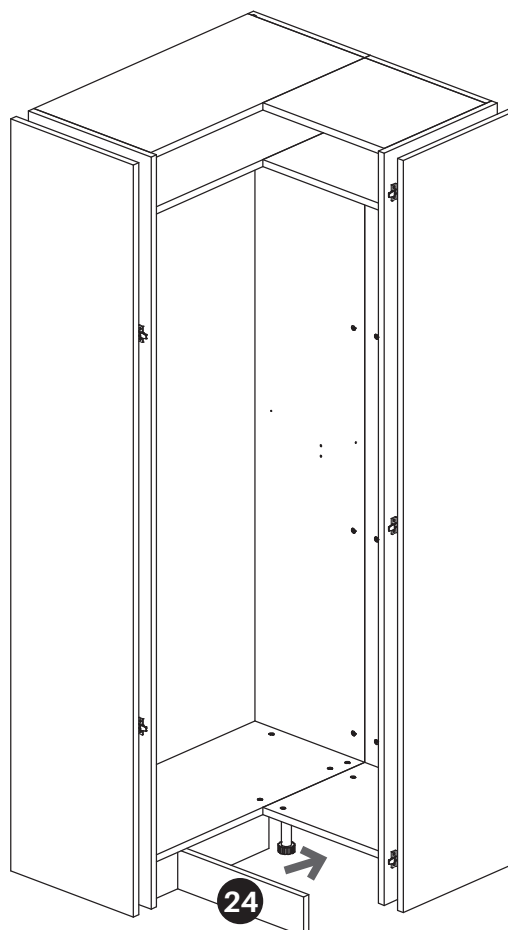
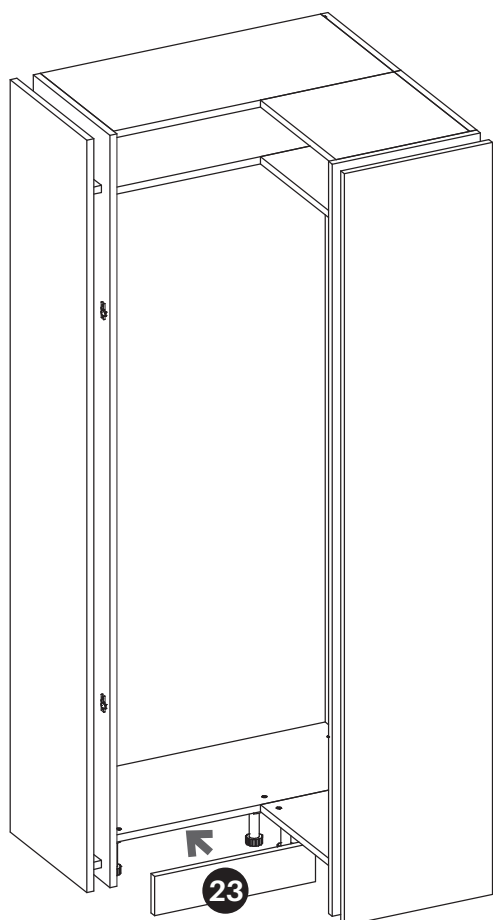



# 32.

## OUTILS

tournevis



## QUINCAILLERIE

Sachet n°828

P	support tringle	x2
F	vis	x2

⚠ Les vis sont à visser sans pré-perçage préalable.

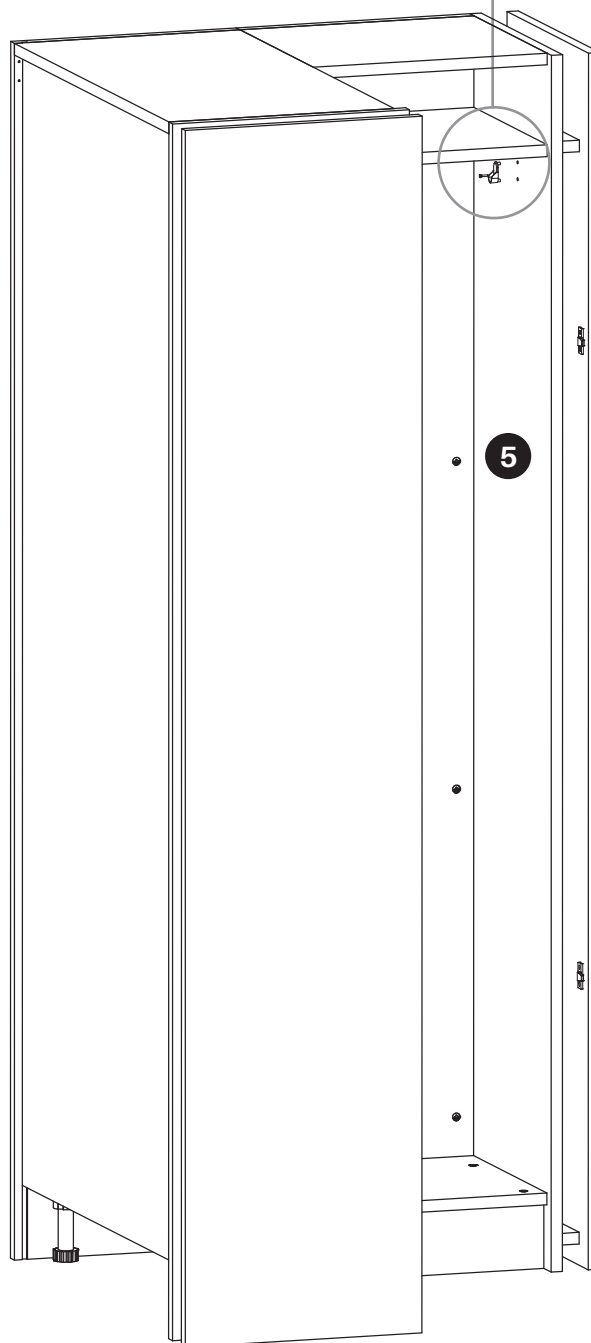
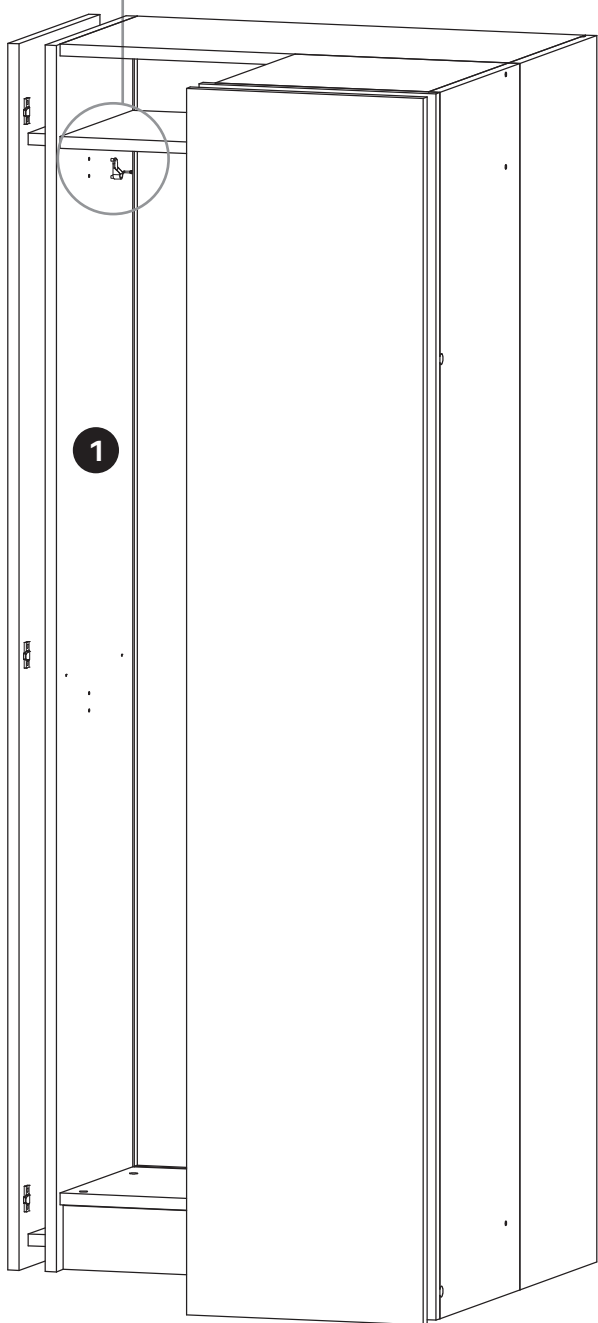
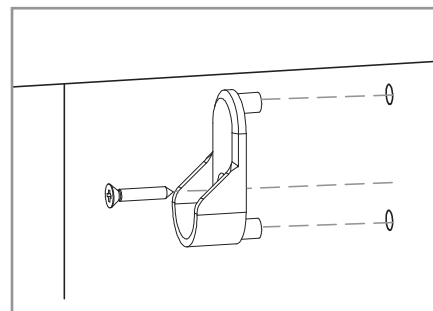
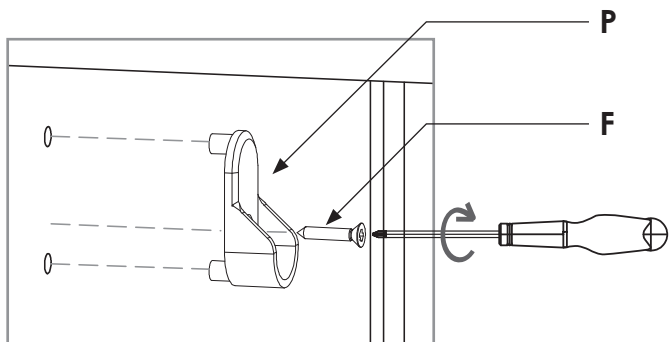

# 33.

## OUTILS

tournevis



## QUINCAILLERIE

Sachet n°850

U	coude de jonction	x1
V	support sous tablette	x1
F	vis	x2

### ÉTAPE 1

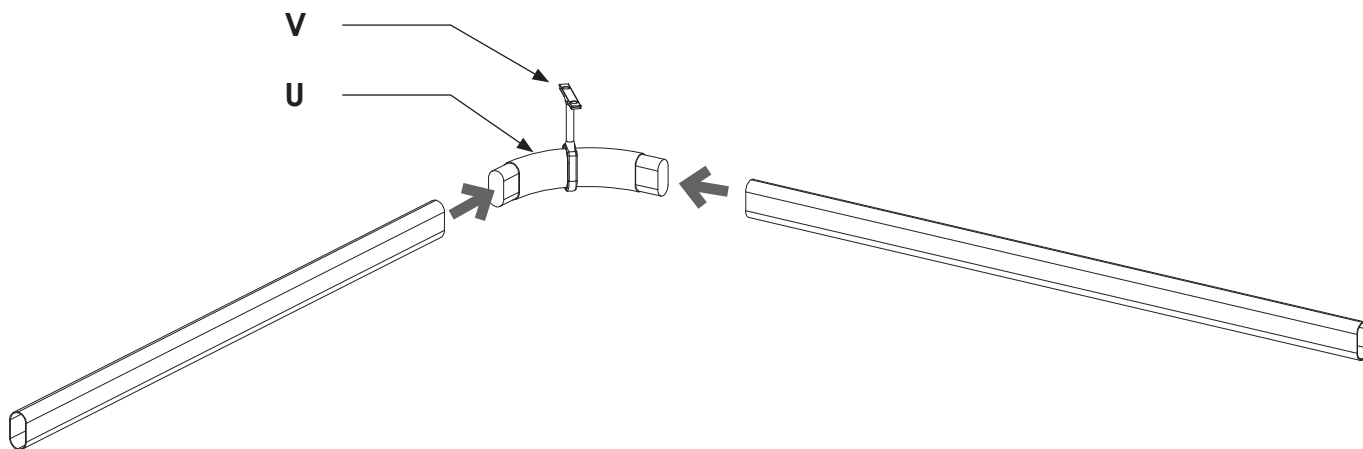

### ÉTAPE 2

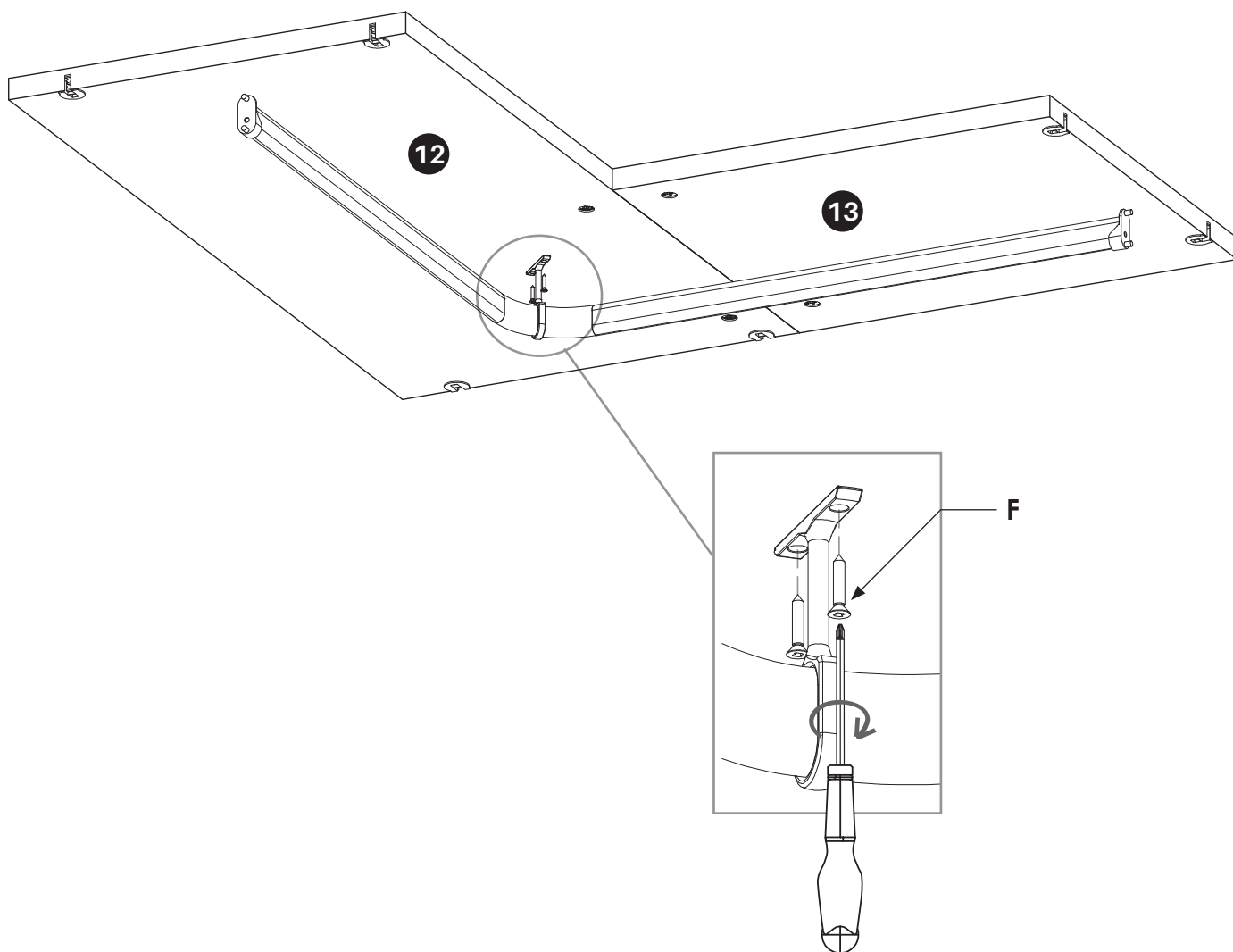

# 34.

## OUTILS

maillet

tournevis



## QUINCAILLERIE

Sachet n°804

L

boitier

x4

Sachet n°804

M

goujon

x4

### ÉTAPE 1

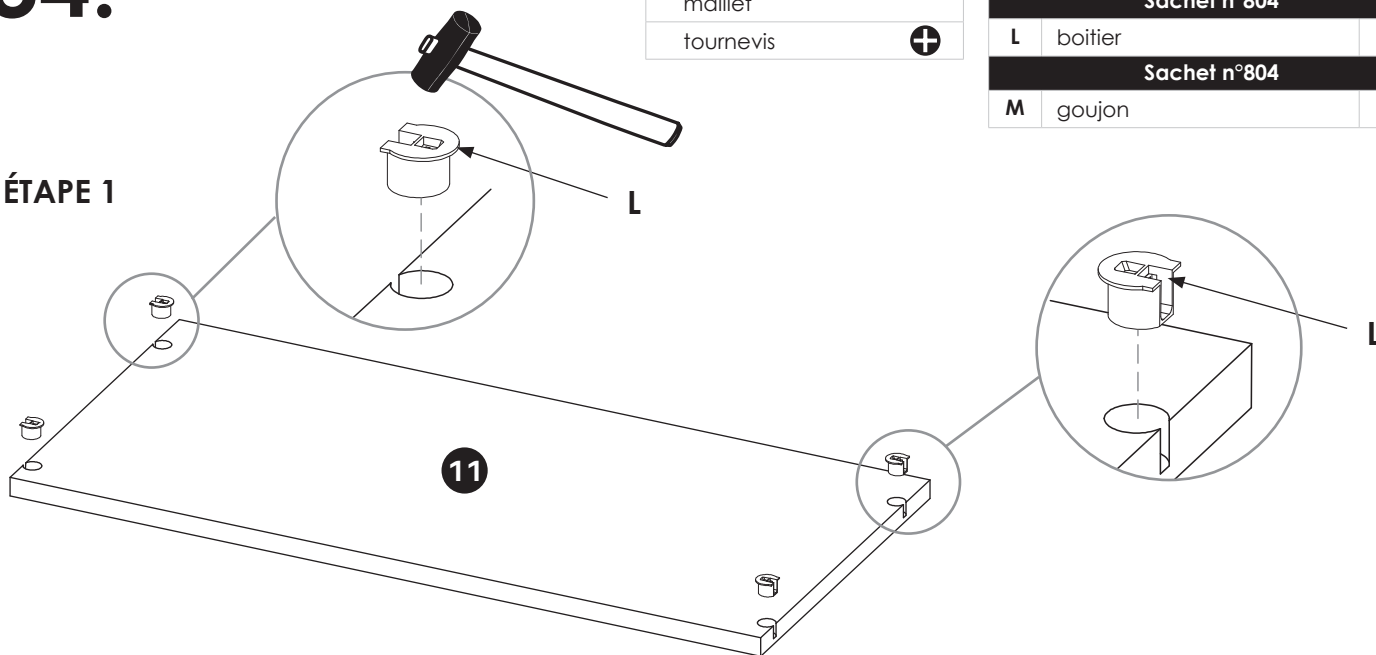

ÉTAPE 2 : Répéter les étapes 16. et 30.

# 35.

## OUTILS

tournevis



## QUINCAILLERIE

Sachet n°828

P

support tringle

x2

F

vis

x2

Répéter l'étape 32. dans les joues 1 et 5 pour fixer la tringle droite sous la tablette 11.

⚠ Les vis sont à visser sans pré-perçage préalable.

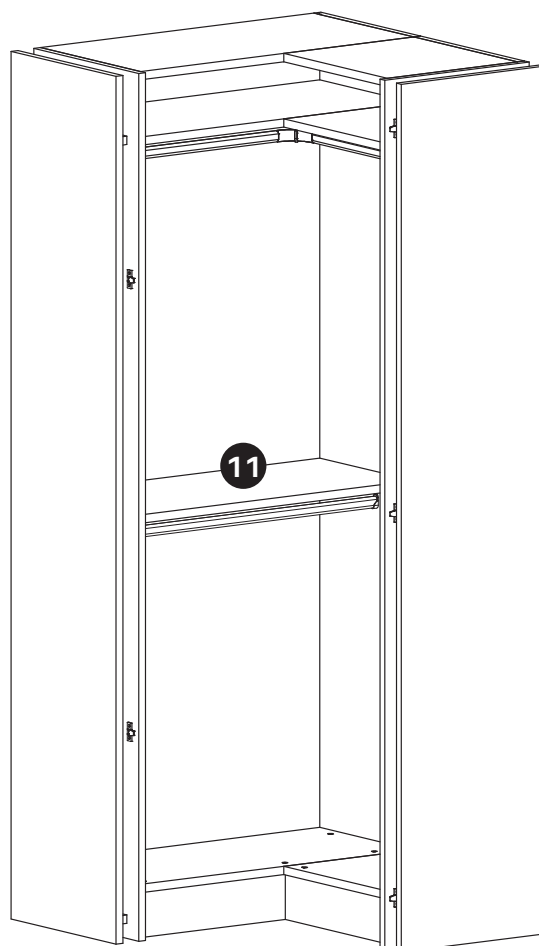
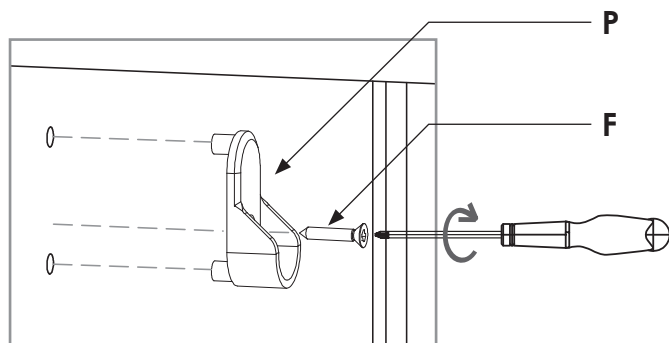

Si **MEUBLE D'ANGLE** utilisé seul : passer à l'étape **36a**.

Si **MEUBLE D'ANGLE** utilisé avec un Konsilio à droite et/ou à gauche : passer à l'étape **36b**.

# 36a.

## OUTILS

tournevis



## QUINCAILLERIE

Sachet n°834

x2

Q ferrure femelle

x10

F vis

x20

### ÉTAPE 1

x2

2 et 16 : largeur 100 mm

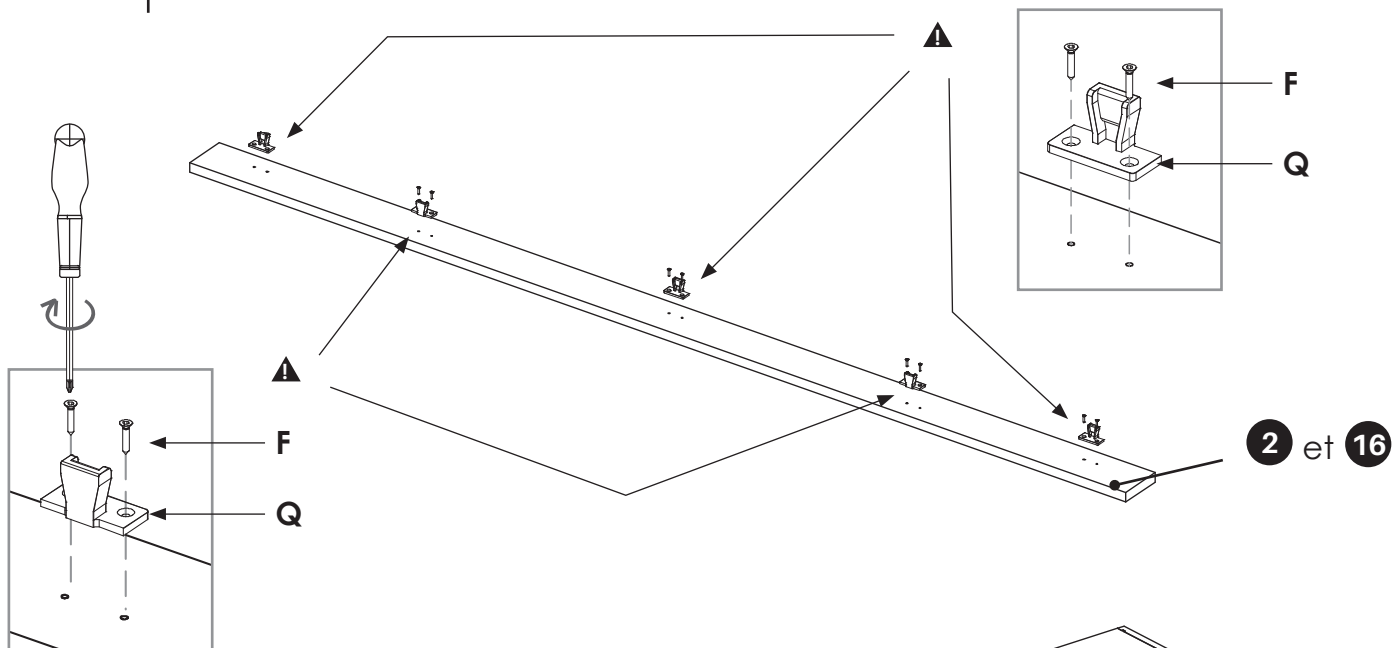

### ÉTAPE 2 : Positionner les montants 2 et 16

#### VUE DE DESSUS

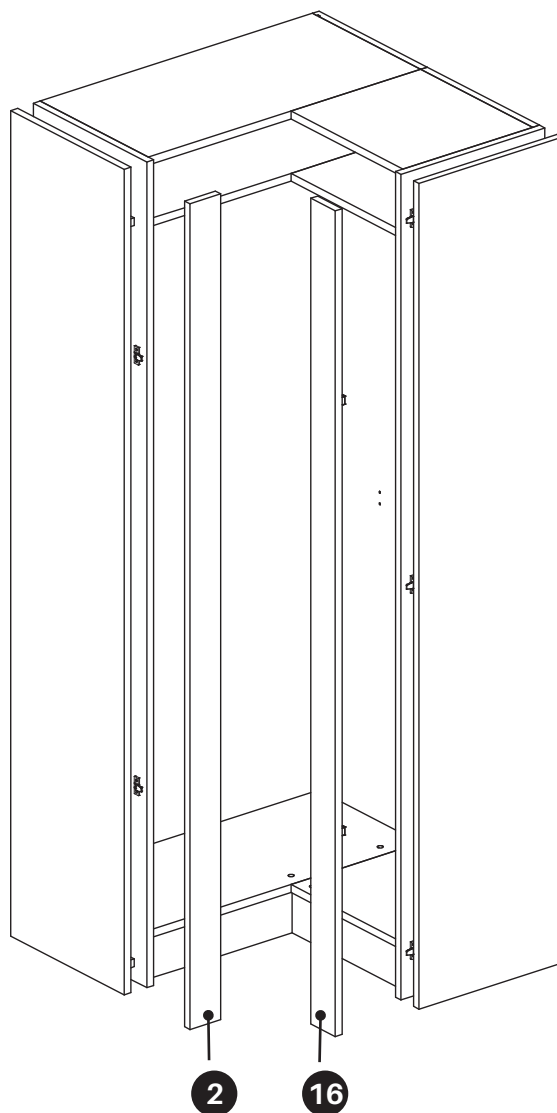
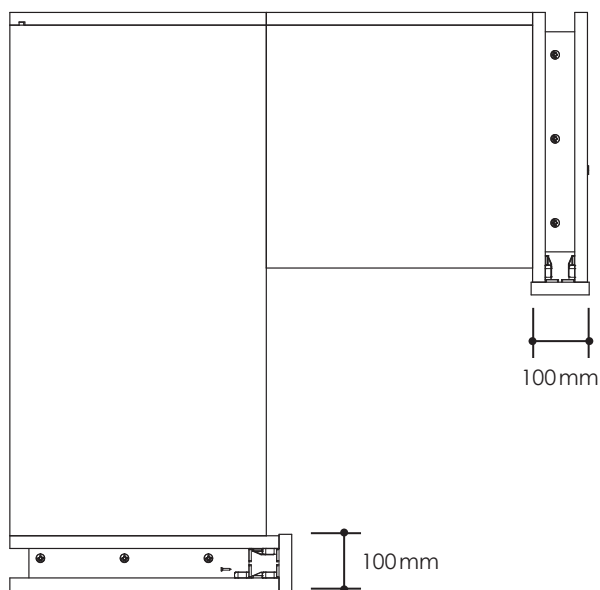

# 36b.

## OUTILS

tournevis



## QUINCAILLERIE

	Sachet n°834	x2
Q	ferrure femelle	x10
F	vis	x20

Monter l'espace d'angle en premier, à l'exception des montants larges.

ÉTAPE 1 : 21 et 22 : largeur 122 mm

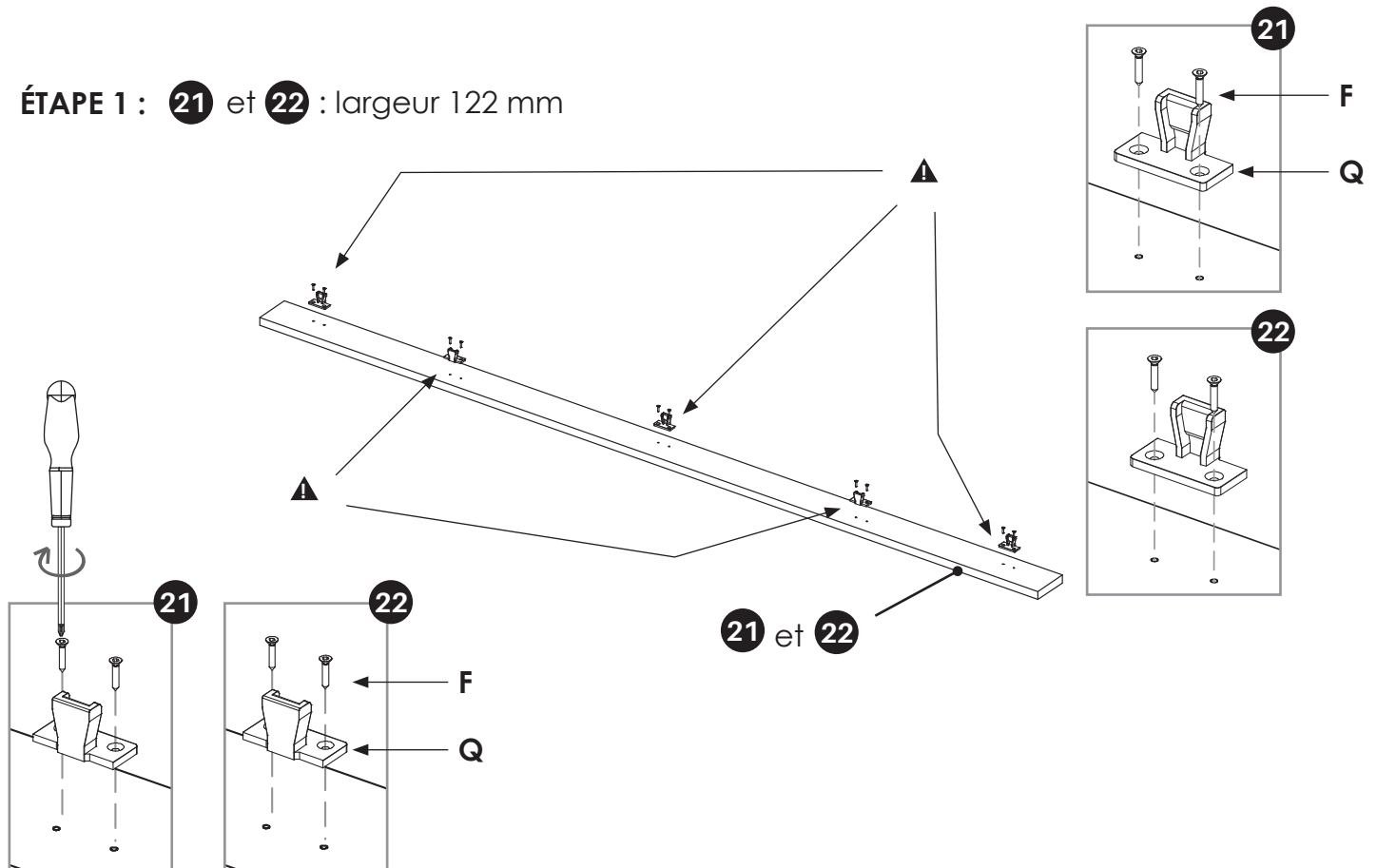

ÉTAPE 2 : Positionner les montants 21 et 22 afin que ce(s) dernier(s) recouvre(nt) la/les joue(s) externe(s) du/des Konsilio.

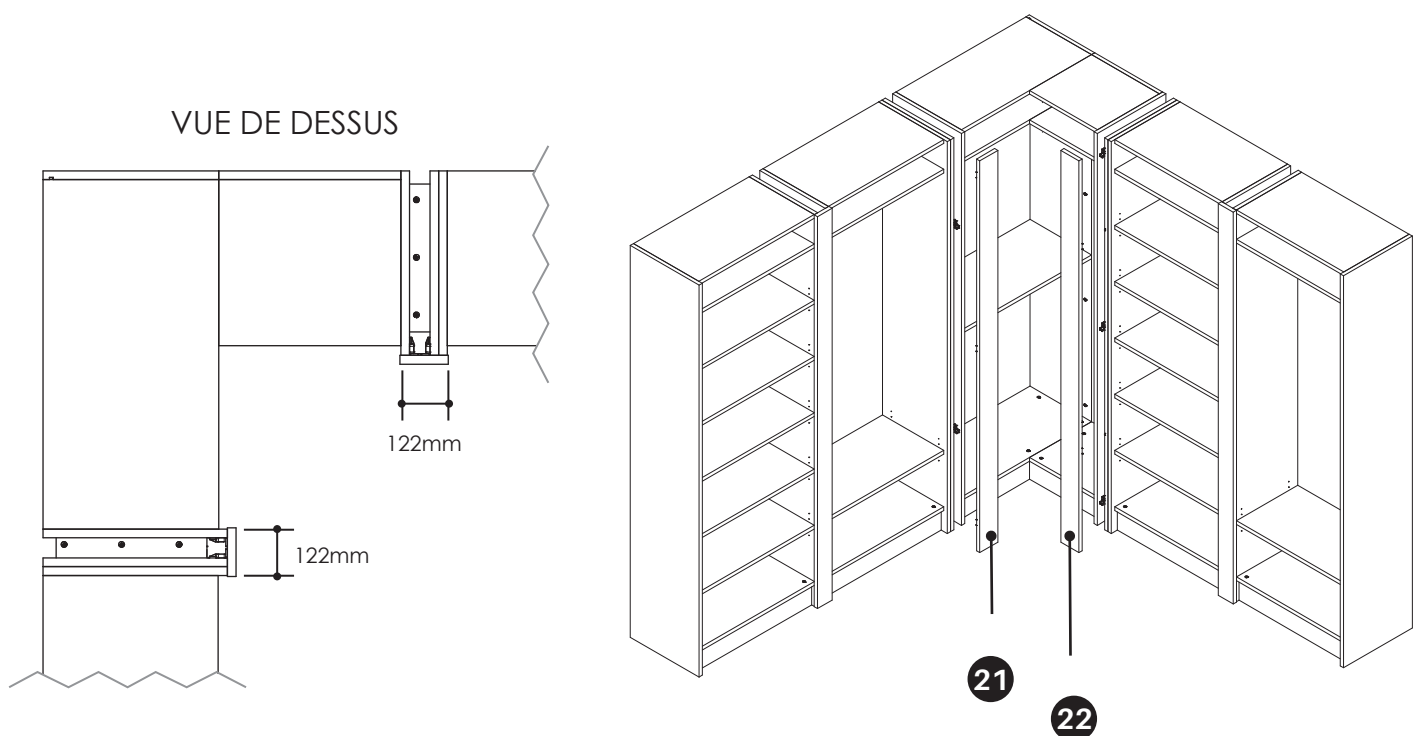

## KAZED À VOTRE ÉCOUTE



05 49 25 40 29



SAS KAZED  
45 allée des Grands Champs  
CS90066  
79260 La Crèche



[www.kazed.fr](http://www.kazed.fr)  
[www.kazed.store](http://www.kazed.store)

 **Kazed**

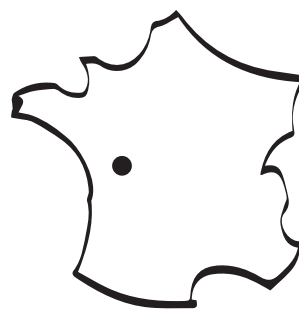

**LE TRI**  
**+ FACILE**



NOTICE



BAC  
DE  
TRI

KAZED-E499-06-2024 - NOTICE.548 - Crédit photo : KAZED

